

Electrical Power Design Guide

Benchmark[®] Boilers

Models 750 through 6000

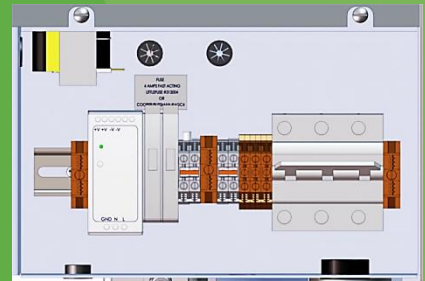

Other documents for this product include:

OMM-0127 BMK750K-3000K Installation-Startup KOREA
OMM-0128 BMK750K-3000K Operation- Maintenance KOREA
OMM-0136 BMK750-6000 Platinum-Edge Installation-Startup
OMM-0137 BMK750-6000 Platinum-Edge Operation-Service
OMM-0138 BMK750-6000 Platinum-Edge Reference Manual

TAG-0019 Benchmark Boiler Application Guide
TAG-0022 Benchmark Vent & Combustion Air Guide
TAG-0047 Benchmark Gas Guide

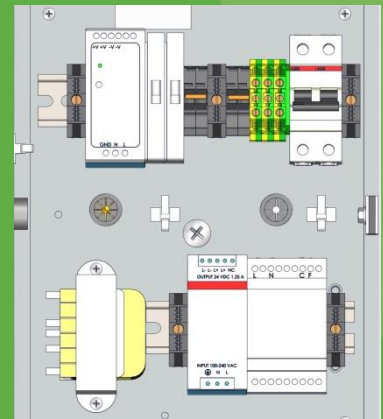

Disclaimer

The information contained in this manual is subject to change without notice from AERCO International, Inc. AERCO makes no warranty of any kind with respect to this material, including, but not limited to, implied warranties of merchantability and fitness for a particular application. Some states do not allow the exclusion or limitation of incidental or consequential damages, so the above limitation may not apply. AERCO is not liable for errors appearing in this manual, not for incidental or consequential damages occurring in connection with the furnishing, performance, or use of these materials.

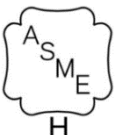

1. GENERAL

Benchmark (BMK) Gas Fired Boilers are fully factory wired packaged units which require simple external power wiring as part of the installation (Figure 1). This technical guide is intended to help designers provide electrical power wiring (line voltage) to Benchmark units. Control wiring details are provided in other publications, depending upon unit application. This document is intended only as a guide and therefore cannot include all possible alternatives or unit applications. In order to comply with all codes and authorities having jurisdiction, designers and installers must plan the electrical wiring carefully and execute the installation completely. Emergency shutoffs, fusible fire switches, break glass stations, and other electrical requirements should be considered and installed whenever necessary.

2. BOILER ELECTRICAL REQUIREMENTS

Benchmark boilers are available with the following power options:

BMK Model	Voltage	Phase	Amperage ¹	Electrical Req.	Electrical Req.	Electrical Req.	Electrical Req.
				120V/1PH/60Hz	208V/3PH/60Hz	460V/3PH/60Hz	575V/3PH/60Hz
BMK750 – 1000 Dom.	120 V	1Ø / 60 Hz	15	13 FLA	-	-	-
BMK750 – 1000 Intl'	220 V	1Ø / 50-60 Hz	20	13 FLA	-	-	-
BMK1500 – 2000 Dom.	120 V	1Ø / 60 Hz	20	16 FLA	-	-	-
BMK1500 – 2000 Intl'	220 V	1Ø / 50-60 Hz	20	16 FLA	-	-	-
BMK2500 - 3000 Dom.	208 V	3Ø / 60 Hz	20	-	10 FLA	5 FLA	-
	480 V	3Ø / 60 Hz	15	-	10 FLA	5 FLA	-
BMK2500 - 3000 Intl'	380-415 V	3Ø / 50-60 Hz	15	-	10 FLA	5 FLA	-
BMK4000 – 5000N DOM	208 V	3Ø / 60 Hz	40	-	23 FLA	12 FLA	-
	480 V	3Ø / 60 Hz	20	-	23 FLA	12 FLA	-
BMK4000 – 5000N Intl'	380-415 V	3Ø / 50-60 Hz	20	-	23 FLA	12 FLA	-
BMK5000 - 6000 Dom.	208 V	3Ø / 60 Hz	30	-	19 FLA	9 FLA	7 FLA
	480 V	3Ø / 60 Hz	20	-	19 FLA	9 FLA	7 FLA
BMK5000 - 6000 CAN.	575 V	3Ø / 60 Hz	20	-	19 FLA	9 FLA	7 FLA
BMK5000 - 6000 Intl'	380-415 V	3Ø / 50-60 Hz	20	-	19 FLA	9 FLA	7 FLA

¹ Breaker Rating

Voltages lower than those specified in the table above will result in increased wear and premature failure of the blower motor. Wire size and type should be made per the National Electrical Code based on length and load.

For all Benchmark models, the power box for field wiring connections is located in the upper right corner behind the unit front panel. All copper wire must be connected to the power box.

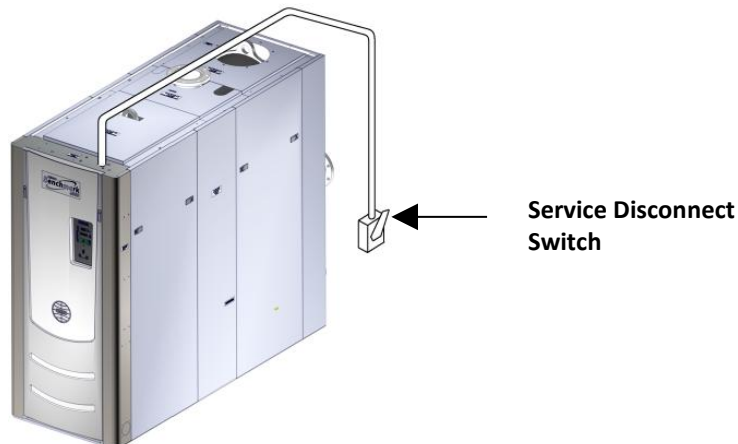

Figure 1: Service Disconnect Switch Typical Location

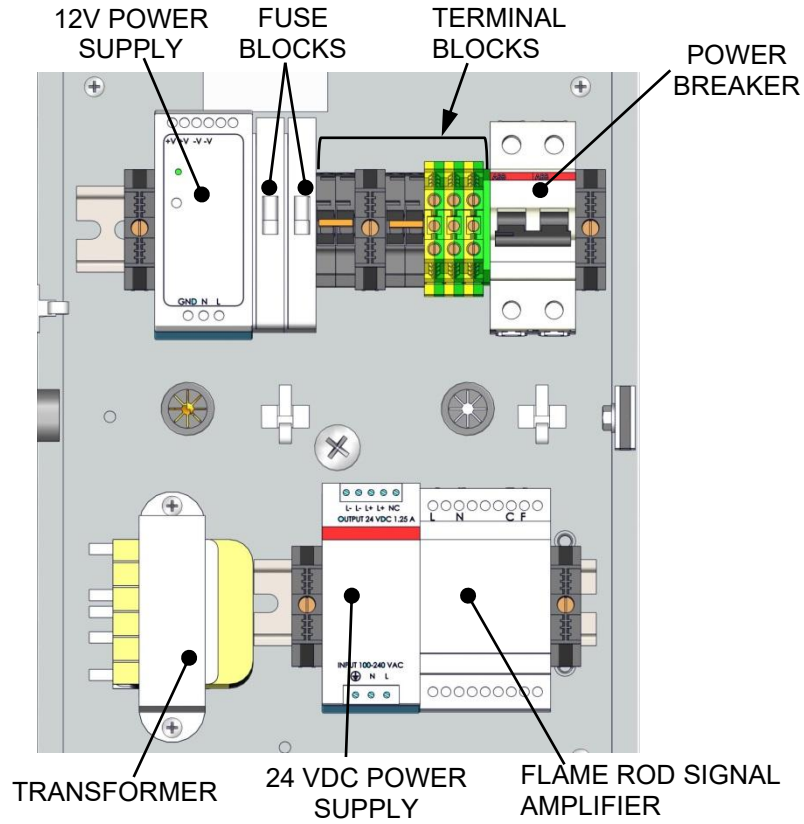

Figure 2a: Power Box Components, BMK750 & 1000 – DOMESTIC

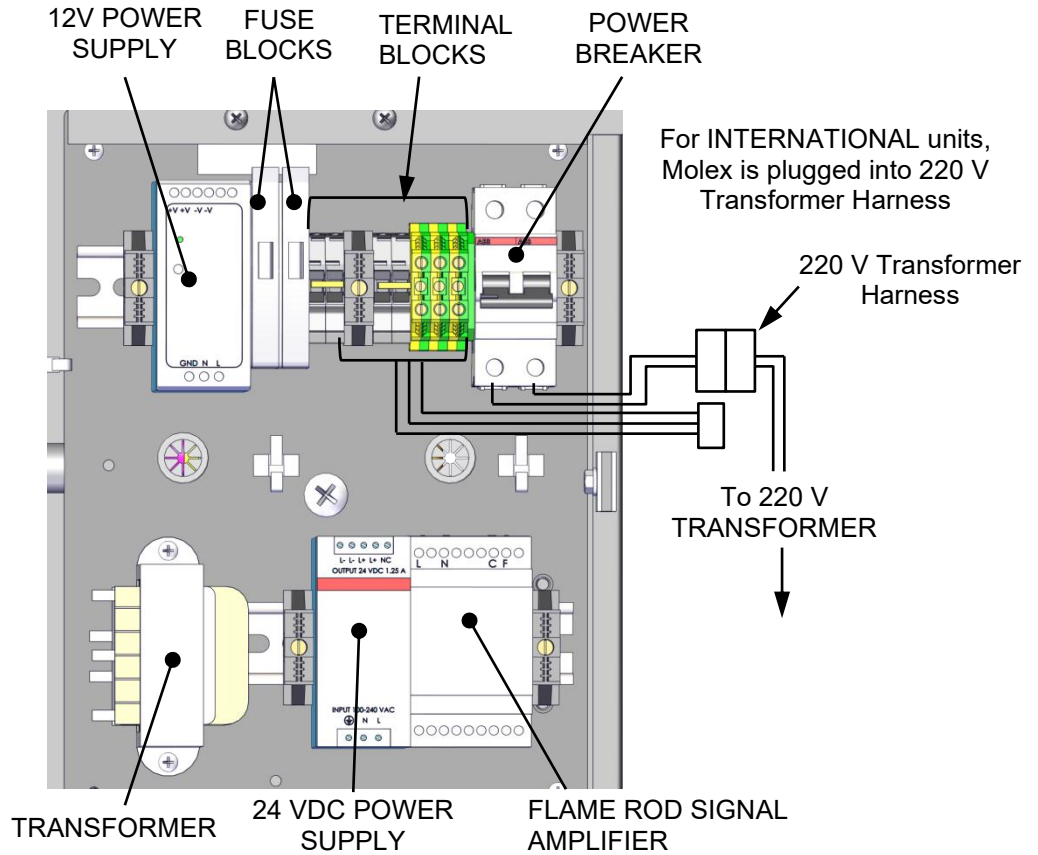

Figure 2b: Power Box Components, BMK750 & 1000 – INTERNATIONAL

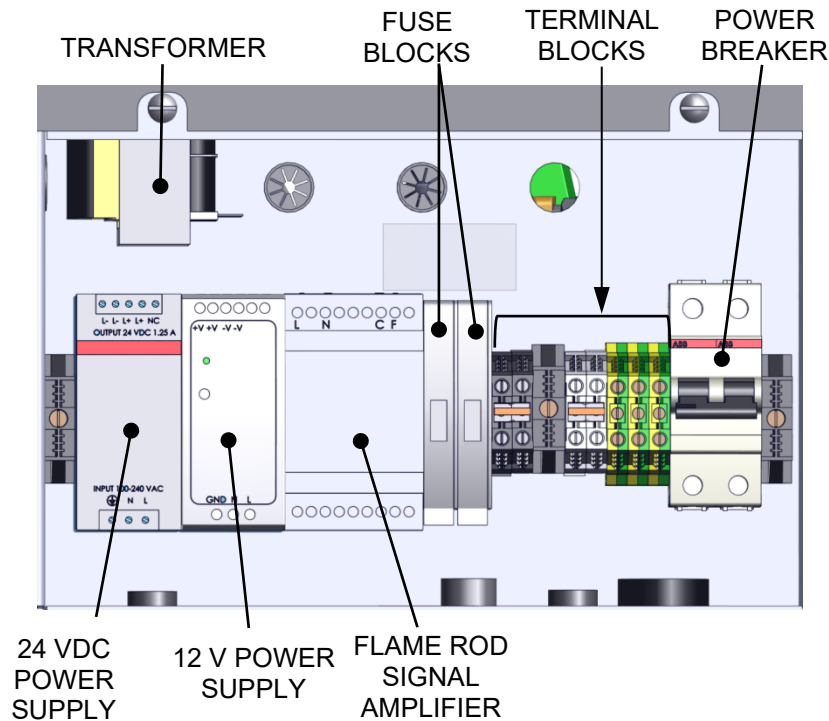

Figure 3a: Power Box Components, BMK1500 – 2000 – DOMESTIC

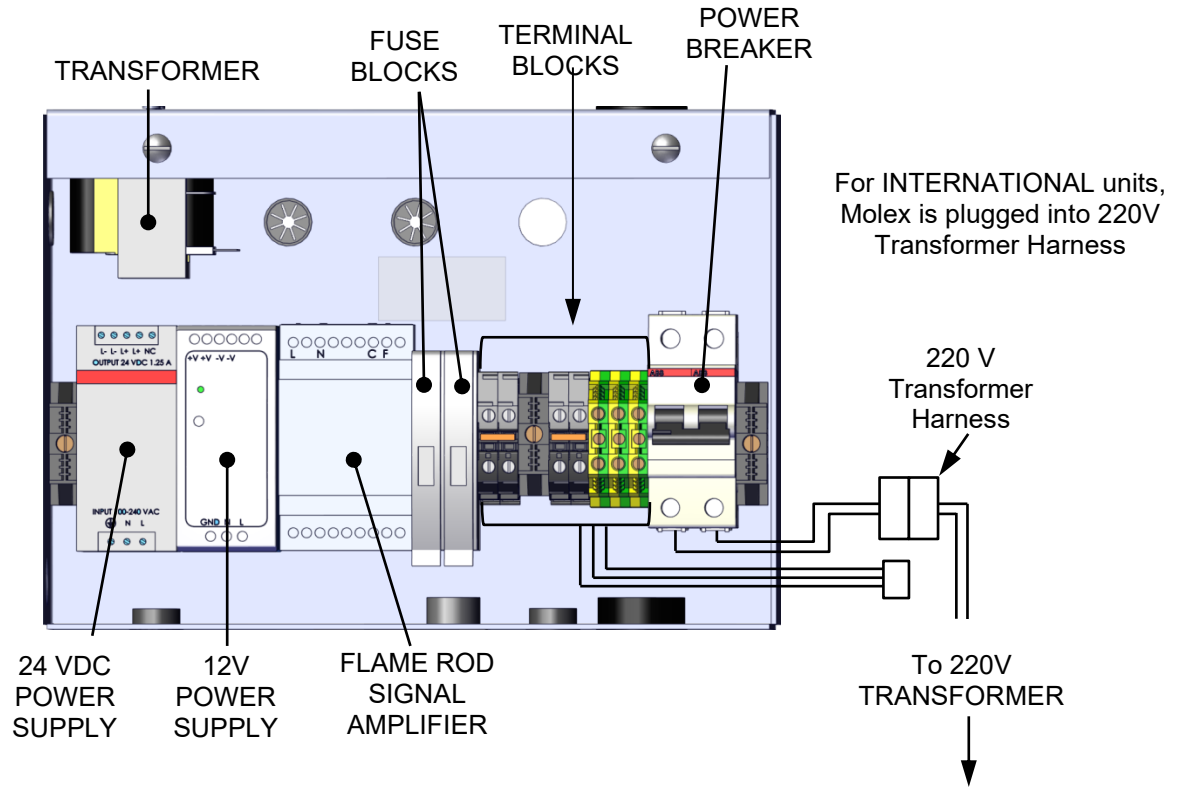

Figure 3b: Power Box Components, BMK1500 – 2000 – INTERNATIONAL

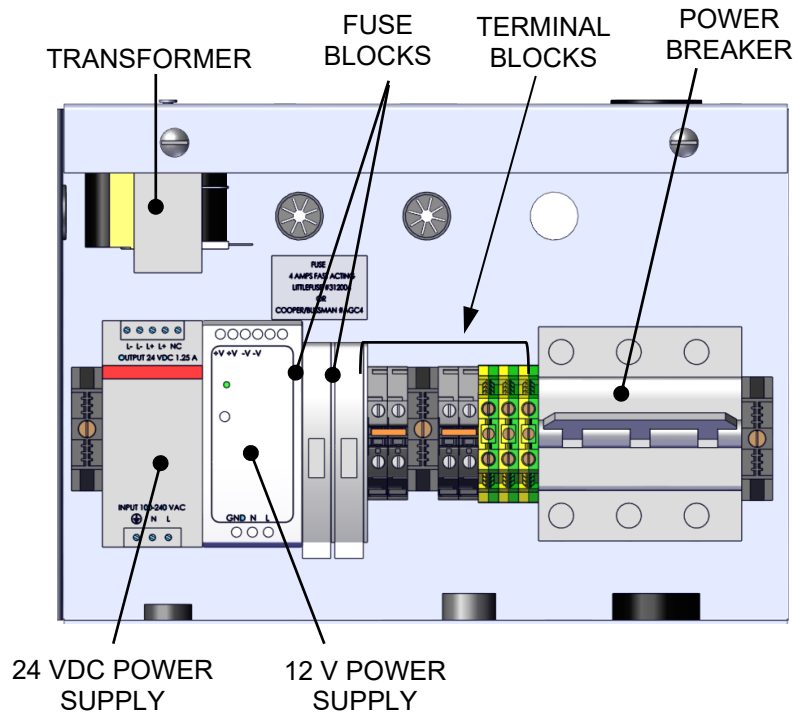

Figure 4: Power Box Components, BMK2500 – 6000 (Domestic & International)

3. PROVISIONS FOR SERVICE

Designers must provide emergency shutoffs and other devices to satisfy electrical codes. It is also recommended to provide an electrical shutoff disconnect switch of suitable load carrying characteristics near each BMK boiler. No electrical boxes or field components should be mounted to the surface of the boiler or where they would interfere with the removal of the side or top panels for maintenance. The service disconnect switch should be mounted near the unit, as illustrated in Diagram 1. Wiring conduit, EMT, or other wiring paths should not be secured to the unit but supported externally. Electricians should be instructed as to where the wiring conduit should be located, such as away from the relief valve discharge, drains, etc. All electrical conduit and hardware should be installed so that it does not interfere with the removal of any covers, inhibit service or maintenance, or prevent access between the unit and walls or another unit.

4. BOILER WIRING

A dedicated protected circuit, sized for the amperage values below, should be provided to the boiler. No other electrical devices should be permanently wired on the same circuit.

An emergency switch (electrical shutoff) must be wired in series with power to the unit. Connecting an emergency shutoff switch (E-stop) to the main power terminals of the boiler is the safest way to disable and un-power the unit. Use of the remote interlock, located on the I/O board, is not recommended since it does **not** cutoff power within the unit, it only disables it. Under no circumstance should the remote interlock of the BST Manager unit be used as an emergency switch for the plant.

Multiple Unit Wiring: When multiple units are installed within the same mechanical spaces, electrical code requirements call for a single electrical shutoff for emergency use. It is the responsibility of the electrical designer to comply with local codes and regulations affecting an individual installation.

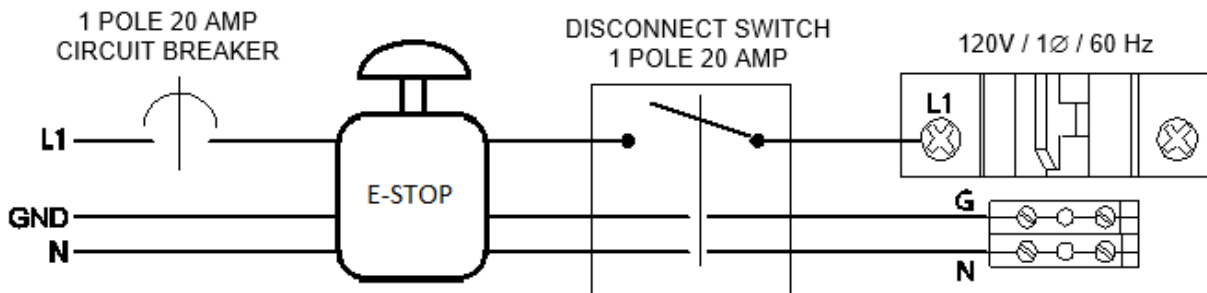

The following table lists the input power requirements for all Benchmark boilers, including the diagram number of each model's corresponding schematic diagram:

BMK Model	DOMESTIC UNITS				INTERNATIONAL UNITS			
	Diag.	Voltage/Phase/Frequency	Amps	Wires	Diag.	Voltage/Phase/Frequency	Amps	Wires
750 – 2000	1a	120V / 1Ø / 60 Hz@	15 A	3	1b	220V / 1Ø / 50- 60 Hz	20 A	3
			20 A					
2500/3000	5	208V / 3Ø / 60 Hz	20 A	4	5	380-415V / 3Ø / 50- 60 Hz	15 A	4
	4	480V / 3Ø / 60 Hz	15 A	4				
4000/5000N	2	208 V / 3Ø / 60 Hz	40 A	4	5	380-415V / 3Ø / 50- 60 Hz	20 A	4
	4	480V / 3Ø / 60 Hz	20 A	4				
5000/6000	2	208V / 3Ø / 60 Hz	30 A	4	5	380-415V / 3Ø / 50-60 Hz	20 A	4
	3	480V <u>or</u> 575V / 3Ø / 60 Hz	20 A	4				

For applicable wiring connections, refer to the schematic diagrams below.

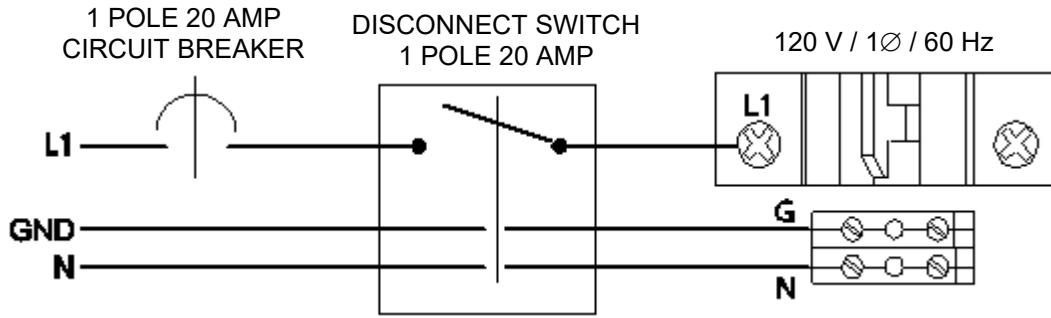

Diagram 1a - BMK750-2000: 120 V / 1Ø / 60 Hz Wiring Schematic – 3 Wire – DOMESTIC

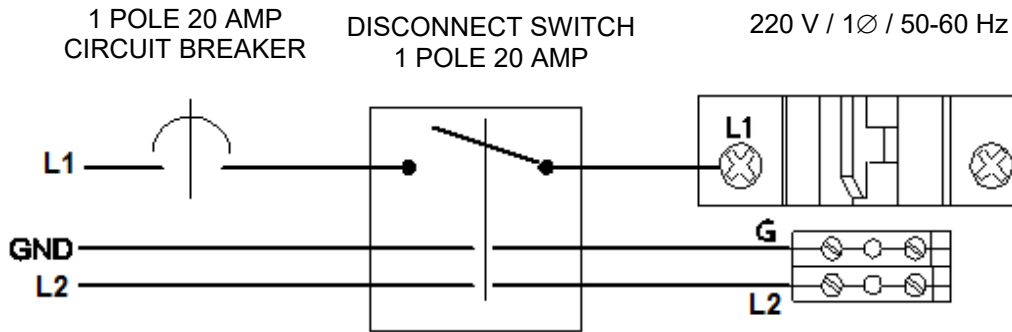

Diagram 1b - BMK750-2000: 220 V / 1Ø / 50-60 Hz Wiring Schematic – 3 Wire – INTERNATIONAL

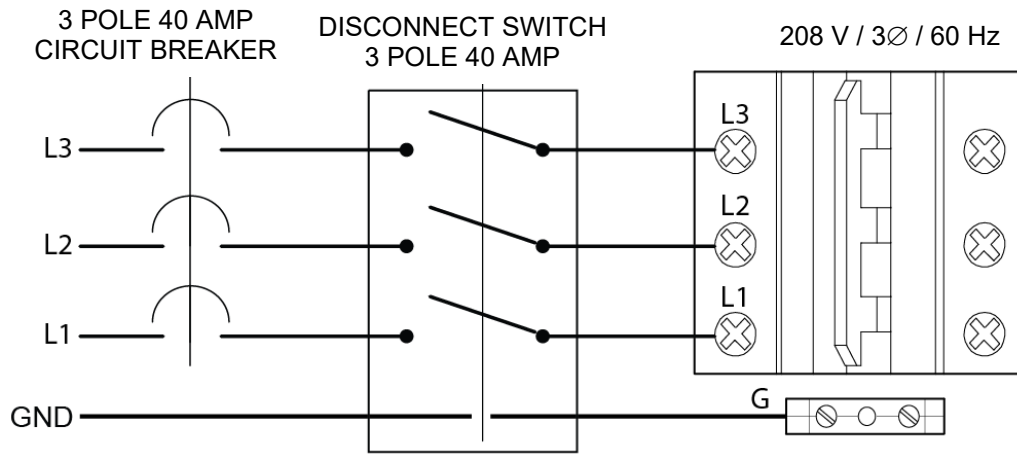

Diagram 2 - BMK2500-6000: 208 V / 3Ø / 60 Hz Wiring Schematic- 4 Wire – DOMESTIC

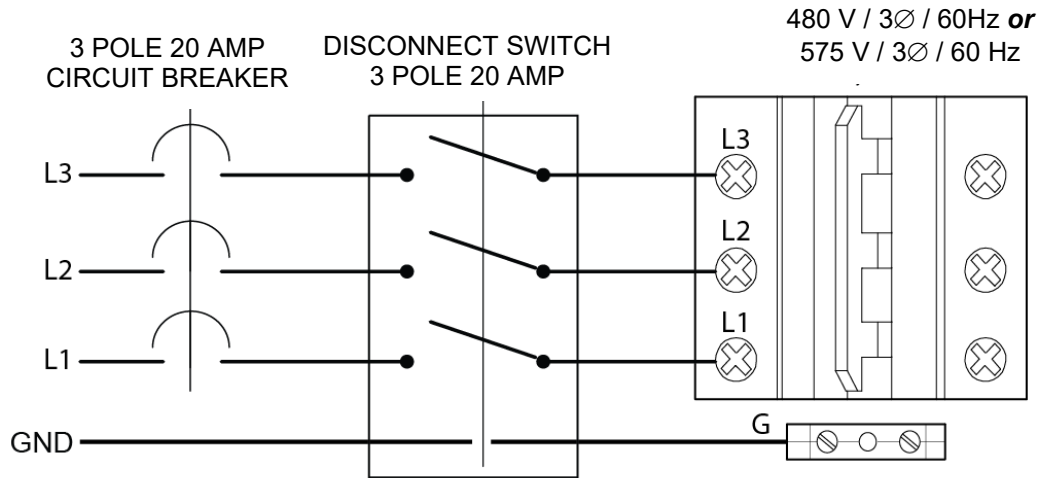

Diagram 3: BMK5000/6000: 480 V or 575 V / 3Ø / 60 Hz Wiring Schematic- 4 Wire – DOMESTIC

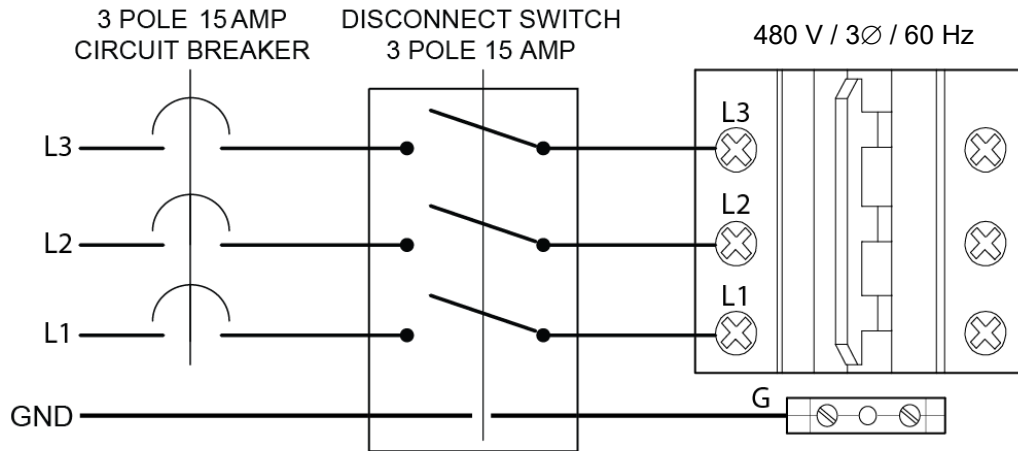

Diagram 4 – BMK2500-5000N: 480 V / 3Ø / 60 Hz Wiring Schematic- 4 Wire – DOMESTIC

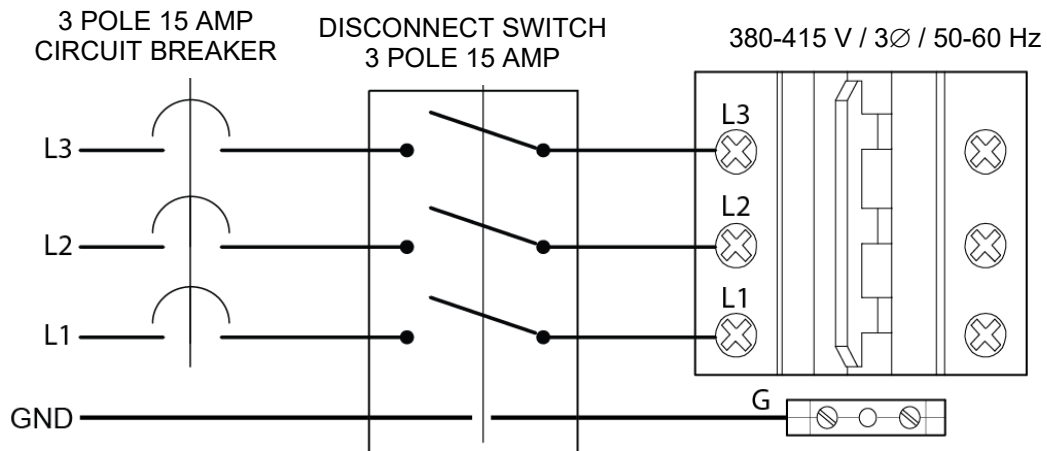

Diagram 5 – BMK2500-6000: 380-415 V / 3Ø / 50-60 Hz Wiring Schematic- 4 Wire – INTERNATIONAL



© AERCO International, Inc., 2026