

## Application Design Guide

# Benchmark<sup>®</sup> Boilers with Edge [ii] Controller

Models 750 through 6000

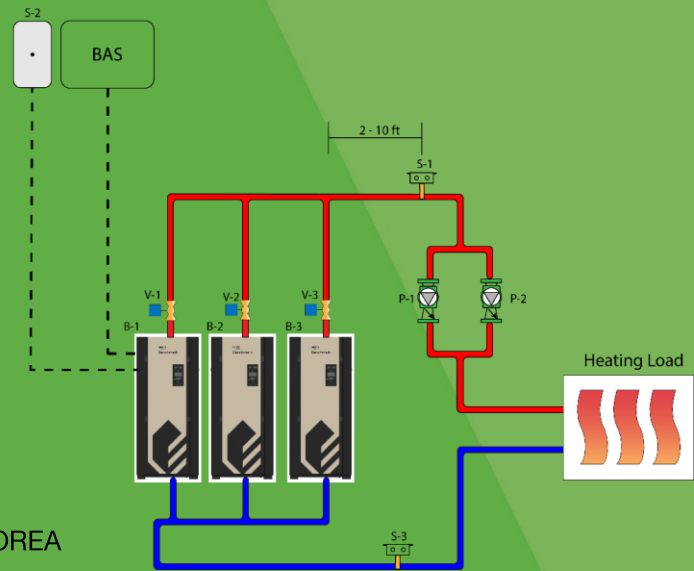

### Other documents for this product include:

- OMM-0127 BMK750K-3000K Installation-Startup KOREA
- OMM-0128 BMK750K-3000K Operation- Maintenance KOREA
- OMM-0136 BMK750-6000 Edge [II] Installation-Startup
- OMM-0137 BMK750-6000 Edge [II] Operation-Service
- OMM-0138 BMK750-6000 Edge [II] Reference Manual
- OMM-0144 BMK750-6000 Edge [I] Installation-Startup
- OMM-0145 BMK750-6000 Edge [I] Operation-Service
- OMM-0146 BMK750-6000 Edge [I] Reference Manual

- TAG-0022 Benchmark Vent & Combustion Air Guide
- TAG-0047 Benchmark Gas Guide
- TAG-0048 Benchmark Electrical Power Guide

### Disclaimer

The information contained in this manual is subject to change without notice from AERCO International, Inc. AERCO makes no warranty of any kind with respect to this material, including, but not limited to, implied warranties of merchantability and fitness for a particular application. Some states do not allow the exclusion or limitation of incidental or consequential damages, so the above limitation may not apply. AERCO International is not liable for errors appearing in this manual, not for incidental or consequential damages occurring in connection with the furnishing, performance, or use of these materials

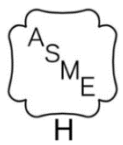

**Table of Contents**

- 1. GENERAL ..... 3
- 2. SINGLE AND MULTIPLE APPLICATIONS ..... 3
- 3. PIPING..... 3
  - 3.1 Pressure and Temperature Ratings ..... 3
  - 3.2 Flow Rate Specifications..... 3
  - 3.3 Pipe Design Provisions ..... 4
  - 3.4 Dual Returns..... 4
- 4. TYPICAL APPLICATIONS ..... 5
  - 4.1 Space Heating ..... 6
  - 4.2 Space Heating (Primary-Secondary Piping)..... 8
  - 4.3 Combination Plant with One Swing Valve and 2-port Buffer Tank..... 11
  - 4.4 Combination Plant with One Swing Valve and 4-port Buffer Tank..... 14
  - 4.5 Combination Plant with 1 Swing Valve + Indirect Storage Tank Water Heater ..... 18
  - 4.6 Combination Plant with Two Swing Valves and 2-port Buffer Tank ..... 21
  - 4.7 Combination Plant with Two Swing Valves and 4-port Buffer Tank ..... 24
  - 4.8 Combination Plant with Two Swing Valves and 4-port Buffer Tank (Primary-Secondary Piping) ..... 27
  - 4.9 Combination Plant with 2 Swing Valves + Domestic Hot Water Tank..... 31
  - 4.10 Combination System w/ 2-Port Buffer Tank & Domestic Summer Pump Mode ..... 34
  - 4.11 Space Heating with Temperature Boost and 4-port Buffer Tank..... 37
  - 4.12 Space Heating with Temperature Boost and Indirect Storage Tank Water Heater ..... 40
- 5. INPUT/OUTPUT REFERENCE DIAGRAM ..... 43

## 1. GENERAL

AERCO Benchmark (BMK) condensing boilers optimizes hydronic system for peak performance and efficiency. They operate with high turndown to match the changing requirements of the energy input, minimize cycling and maximize seasonal efficiency. Their compact footprint allows flexibility and reduce total project installation costs. This guide helps designers apply the BMK boilers to the most common types of systems. If a special application is needed, please call your local AERCO Representative or the AERCO factory for specific application information.

## 2. SINGLE AND MULTIPLE APPLICATIONS

AERCO Benchmark boilers can be applied either as stand-alone single units or in multiple batteries of boilers with unlimited input. Actual boiler sizing and selection are the responsibility of the designer. ASHRAE standards recommend sizing equipment with a minimum of over sizing for maximum system efficiency.

## 3. PIPING

### 3.1 Pressure and Temperature Ratings

The maximum allowable working pressure (MAWP) for the Benchmark boilers are as follows:

BMK Model	MAWP
BMK750 – BMK5000N	160 psig (1103 kPa)
BMK5000 and BMK6000	80 and 150 psig (551 kPa and 1034 kPa) models available

Individual ASME pressure relief valves are supplied on each boiler in setpoints of 30, 50, 60, 75, 100, 125, 150, or 160 psig (207, 414, 517, 689, 862, 1034, or 1103 kPa), as specified. BMK units are applicable to systems with temperatures of 50 °F to 190 °F (10 °C to 88 °C). Due to their condensing design, normal low temperature restrictions do not apply. While most heating applications are designed with a 20 °F (11 °C) temperature drop, BMK boilers are capable of 100 °F (55 °C) temperature drop through the heat exchanger without thermal stress.

### 3.2 Flow Rate Specifications

AERCO BMK boilers require the following minimum flow rate per boiler for proper and stable boiler temperature control operation. To prevent erosion of construction materials, maximum flow per boiler are limited as shown below.

BMK Model	Minimum Flow Rate	Maximum Upper Inlet/Return Flow Rate (If Equipped)*	Combined Dual Return or Single Return Maximum Flow Rate
BMK750	12 gpm (45 lpm)	175 gpm (662 lpm)	175 gpm (662 lpm)
BMK1000	12 gpm (45 lpm)	175 gpm (662 lpm)	175 gpm (662 lpm)
BMK1500	25 gpm (95 lpm)	250 gpm (946 lpm)	250 gpm (946 lpm)
BMK2000	25 gpm (95 lpm)	350 gpm (1325 lpm)	350 gpm (1325 lpm)
BMK2500	25 gpm (95 lpm)	350 gpm (1325 lpm)	350 gpm (1325 lpm)
BMK3000	25 gpm (95 lpm)	350 gpm (1325 lpm)	350 gpm (1325 lpm)
BMK4000/5000N	35 gpm (284 lpm)	500 gpm (1892 lpm)	500 gpm (1892 lpm)
BMK5000/BMK6000	75 gpm (284 lpm)	350 GPM (1325 lpm)	600 gpm (2271 lpm)

**NOTE:** For boilers equipped with dual returns, refer to section 3.4 for additional required provisions.

### 3.3 Pipe Design Provisions

Minimum flow must be observed in piping design. Ancillary flow devices including pumps and valves must be selected and operated to provide minimum flow. Controls (internal boiler controls and/or building automation system) must be configured to operate pumps and valves to allow flow through BMK boilers in operation.

For multiple boiler installations, the piping must be designed to ensure balanced flow through all the boilers. This can be accomplished by using reverse-return piping or a balancing valve at the outlet of each boiler. Failure to balance flow evenly through the boilers will prevent full delivery of boiler capability at design conditions and may cause over-cycling and unnecessary stress on the boilers.

The BMK boiler is approved for zero-side clearance in two-unit pairs in applications where space is at a premium. Piping should be located to allow free access between boilers. For maintenance purposes, each BMK boiler shall have individual valves on supply and return from the system.

When used with a refrigeration (chiller) system, the boilers must be installed to prevent the chilled medium from entering the boiler.

### 3.4 Dual Returns

Benchmark 750-6000 boilers come standard with dual return connections. Utilizing this feature can boost seasonal efficiency by up to 6%. Installations with space heating and the following applications that can take advantage of this feature include:

- Domestic hot water applications
- Higher  $\Delta T$  zones with lower return temperatures
- Air preheat
- Heat pump injection
- And more

Rather than blend the separate zones, the lower return temperature zones/systems could be piped separately to the primary water connection, raising the overall thermal efficiency and allowing the boiler to be in condensing mode for longer periods throughout the year

Multiple flow configurations are possible. There is no minimum flow requirement for the primary low temperature return, as long as the minimum flow requirements of the boiler models are met through the secondary-high temperature return. If the flow split between the high and low temperature returns is constant, the total flow must be no less than the minimum flow requirements of the boiler models. Due to the varying flow conditions possible when utilizing dual returns, AERCO recommends installing check valves at both inlets of the boilers.

## 4. TYPICAL APPLICATIONS

BMK boilers can be used in any closed-loop heating system within their design limitations. The following typical piping and wiring schematic diagrams represent the most common types of installation detail. These diagrams are not intended for any particular system but are rather composites of how AERCO boilers interface with heating and domestic hot water applications in the real world. The designer should incorporate BMK boilers in each system so as to achieve maximum operating efficiency. With ultimate control over the energy transfer process under a broad range of temperatures, the designer should first consider how the system best needs the supplied energy. The boilers should then be applied in the manner that best enables them to use their finite control and capability to supplement the system, using minimum applied energy. The following examples illustrate typical piping and wiring diagrams with brief description of the application and its features:

### IMPORTANT!

For all applications, the header sensor (S-1) must be located 2-10 ft from the nearest boiler.

- Diagram 4-1 – Space Heating
- Diagram 4-2 – Space Heating (Primary-Secondary Piping)
- Diagram 4-3 – Combination Plant with One Swing Valve and 2-port Buffer Tank
- Diagram 4-4 – Combination Plant with One Swing Valve and 4-port Buffer Tank
- Diagram 4-5 – Combination Plant with One Swing Valve and Domestic Hot Water Tank
- Diagram 4-6 – Combination Plant with Two Swing Valves and 2-port Buffer Tank
- Diagram 4-7 – Combination Plant with Two Swing Valves and 4-port Buffer Tank
- Diagram 4-8 – Combination Plant with Two Swing Valves and 4-port Buffer Tank (Primary-Secondary Piping)
- Diagram 4-9 – Combination Plant with Two Swing Valves and Domestic Hot Water Tank
- Diagram 4-10 – Space Heating with Temperature Boost and 2-port Buffer Tank
- Diagram 4-11 – Space Heating with Temperature Boost and 4-port Buffer Tank
- Diagram 4-12 – Space Heating with Temperature Boost and Domestic Hot Water Tank

**NOTE:** For Essential System Setting parameters see *EZ Setup* or *Advanced Setup*.

Address of boilers where pumps, swing valves and DHW sensor are connected must be entered in *EZ Setup* or *Advanced Setup*.

See Edge [ii] Controls manual OMM-0139 for additional information.

See Section 5 for complete Input/Output Reference diagram.

**Concept Drawings:** The following illustrations are only concept drawings, not engineered drawings. They are not intended to describe a complete system, nor any particular system. It is up to the system designer to determine the necessary components for and configuration of the particular system being designed, including ancillary mechanical and control components, and any safety devices which in the judgement of the designer are appropriate, in order to properly size, configure and design that system and to ensure compliance with building and safety code requirements.

## 4.1 Space Heating

**Application Description & Features:** AERCO Benchmark boilers are operated via Boiler Sequencing Technology (BST) to provide space heating. Supply temperature is maintained via constant setpoint, outdoor air reset or remote setpoint command (from building automation system or remote analog signal). Application utilizes AERCO supplied header sensor, sequencing valves and outdoor air sensor; return header sensor is optional.

- The AERCO Edge controller sequences the boiler plant for maximum system efficiency by running as many boilers as available, each operating at its most efficient firing rate.
- Sequencing valves isolate standby boilers, reducing minimum flow requirement.
- Edge[iii] controller supports integration with BAS via BACnet MSTP, BACnet IP, Modbus RTU and Modbus TCP.

### Essential System Settings:

Parameter	Setting
Application	SH ( <i>Space Heating</i> )
SH Operating Mode	Constant Setpoint, Outdoor Air Reset or Remote Setpoint
CASCADE CONFIGURATION-Hdr Temp Sensor	Direct
CASCADE CONFIGURATION-Outdoor Air Temp Sensor ( <i>If SH Operating Mode = Outdoor Air Reset</i> )	Direct
VALVE CONFIGURATION-Select Output	Cascade Valve
VALVE CONFIGURATION-Valve Feedback	Enabled

**Legend:**

- S-1 = Header Sensor
- S-2 = Outdoor Air Sensor
- S-3 = Return Sensor
- P-1a, P-1b = System Pump(s)
- V-1, V-2, V-3 = Sequencing Valves

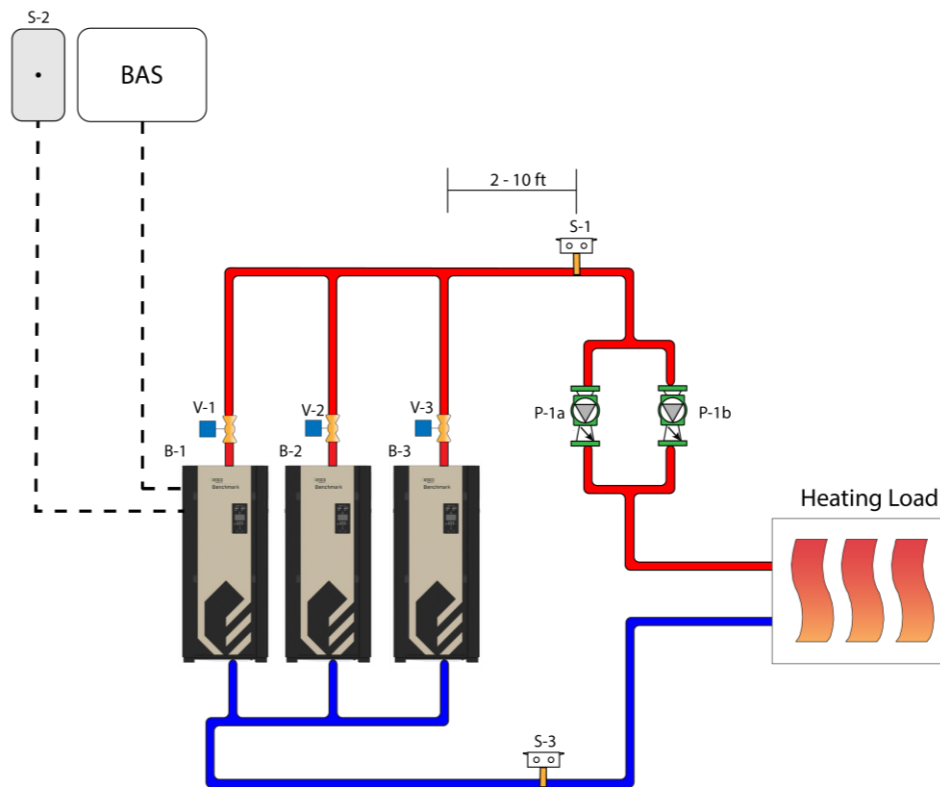

**Diagram 4-1a: Space Heating Piping**

Spare 2 and V2/Spare 1 Relays can be used for ancillary devices such as system pumps, exhaust dampers, exhaust fans, and louvers.

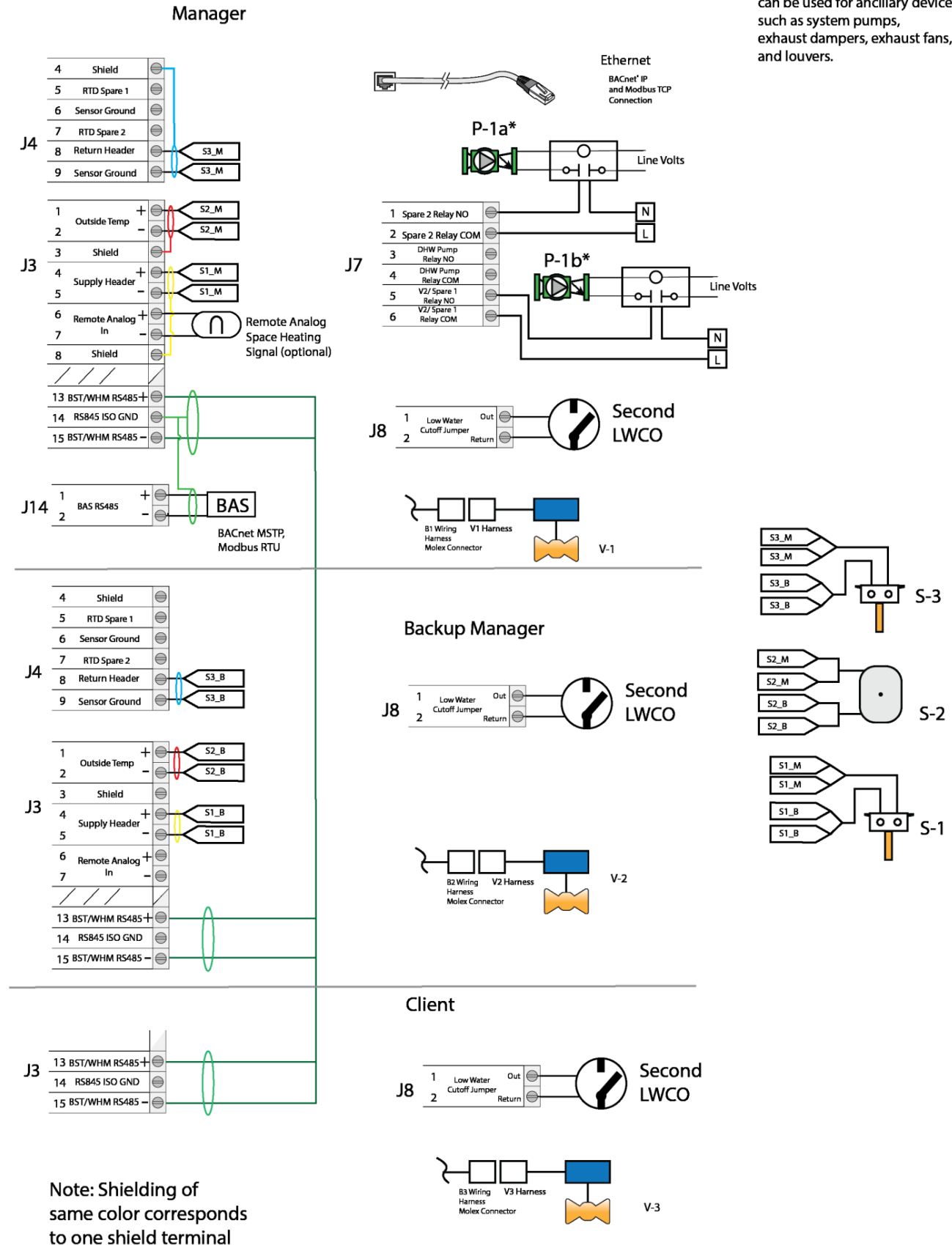

Note: Shielding of same color corresponds to one shield terminal

Diagram 4-1b: Space Heating Wiring

**4.2 Space Heating (Primary-Secondary Piping)**

**Application Description & Features:** Boiler plant is piped in primary-secondary method with individual boiler pumps. Benchmark boilers are operated via Boiler Sequencing Technology (BST) to provide space heating. Supply temperature is maintained via constant setpoint, outdoor air reset or remote setpoint command (from building automation system or remote analog signal). Application utilizes AERCO supplied header sensor and outdoor air sensor; return header sensor is optional (required if VSP Pump Mode=Return Temp).

- The AERCO Edge controller sequences the boiler plant for maximum system efficiency by running as many boilers as available, each operating at its most efficient firing rate.
- Use of variable speed boiler pumps prevents hot water recirculation at the low loss header, resulting to increased efficiency.
- Edge[ii] controller supports integration with BAS via BACnet MSTP, BACnet IP, Modbus RTU and Modbus TCP.

**Note:** For more information on variable speed pump control modes, consult Edge [ii] Controls Manual OMM-0139.

**Essential System Settings:**

Parameter	Setting
Application	Space Heating
SH Operating Mode	Constant Setpoint, Outdoor Air Reset or Remote Setpoint
CASCADE CONFIGURATION-Hdr Temp Sensor	Direct
CASCADE CONFIGURATION-Outdoor Air Temp Sensor <i>(If SH Operating Mode=Outdoor Air Reset)</i>	Direct
VSP Pump Mode	Return Temp or Fire Rate
VSP Piping Configuration	1 Pump Per Blr

**Legend:**  
 S-1 = Header Sensor  
 S-2 = Outdoor Air Sensor  
 S-3 = Return Sensor  
 P-1, P-2, P-3 = Boiler Pumps

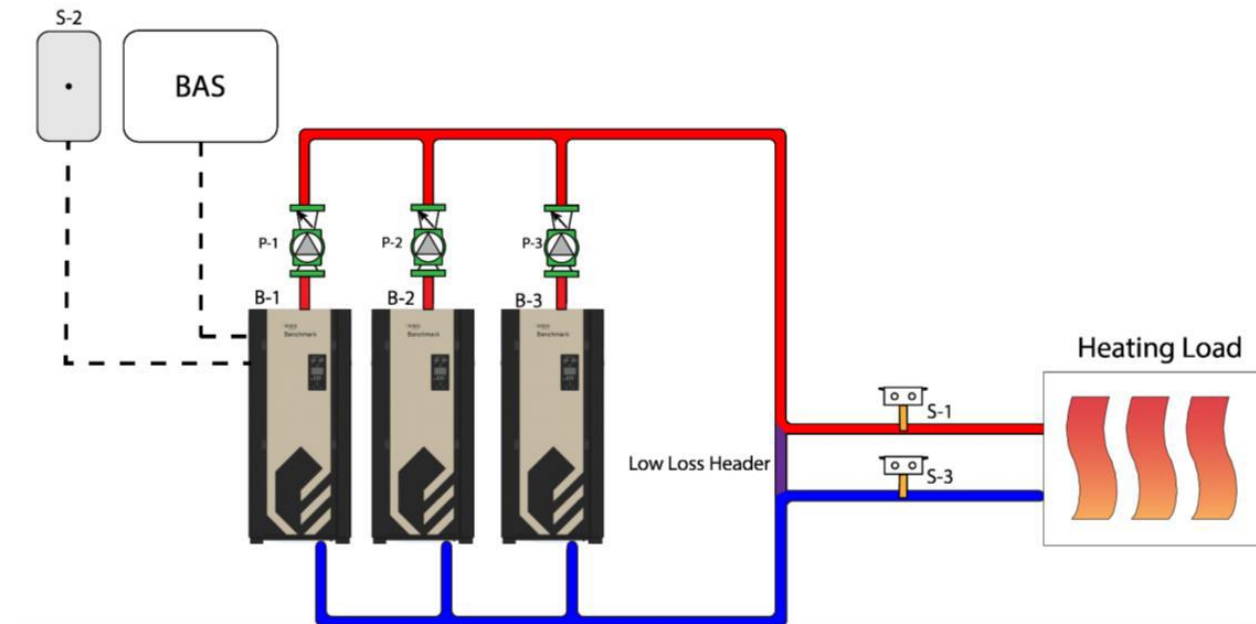
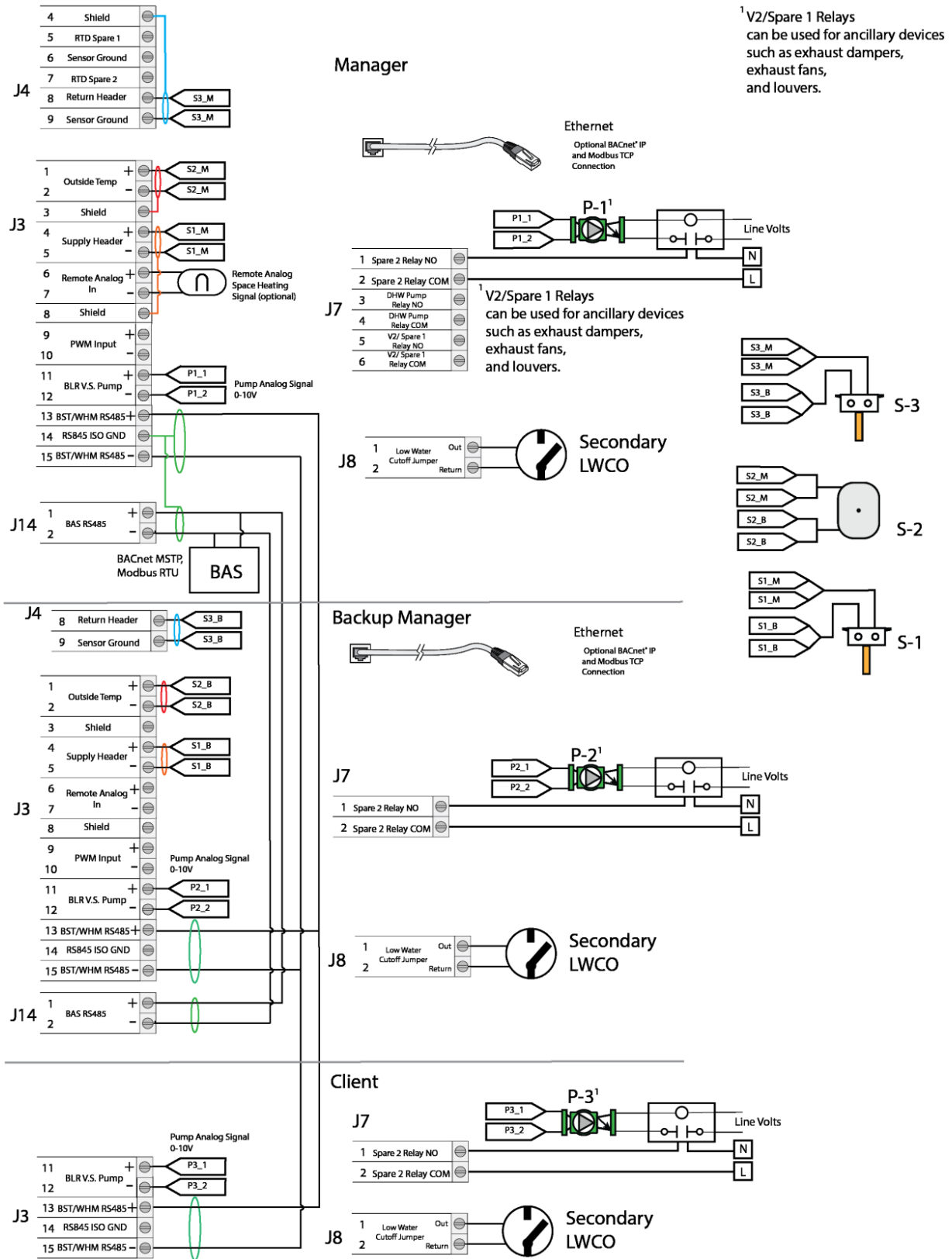

Diagram 4-2a: Space Heating (Primary-Secondary) Piping



**Diagram 4-2b: Space Heating (Primary-Secondary) Wiring**

**4.3 Combination Plant with One Swing Valve and 2-port Buffer Tank**

**Application Description & Features:** Combination plant consists of Benchmark boilers, operated via Boiler Sequencing Technology (BST) to provide space heating. Supply temperature is maintained via constant setpoint, outdoor air reset or remote setpoint command (from building automation system or remote analog signal). Domestic hot water is generated using AERCO SmartPlate EV water heaters; DHW boiler sensor is used for controlling domestic boiler loop temperature. Swing boiler is assigned to serve the water heater by default and assist in space heating when domestic hot water load is satisfied. Swing valve separates boilers serving domestic hot water from space heating. DHW boiler pump runs continuously to provide boiler water to the water heaters. 2-port buffer tank is utilized to dampen out fast domestic load transitions and minimize boiler cycling. Application utilizes AERCO supplied header sensor, sequencing valves and outdoor air sensor; return header sensor is optional.

- The AERCO Edge Controller sequences the boiler plant for maximum system efficiency by running as many boilers as available, each operating at its most efficient firing rate.
- The swing boiler serves the domestic hot water by default and may be used to implement "N+1" sizing method for space heating.
- Sequencing valves isolate standby boilers from the system, reducing the system’s minimum flow requirement.
- Edge[iii] controller supports integration with BAS via BACnet MSTP, BACnet IP, Modbus RTU and Modbus TCP.

**Essential System Settings**

Parameter	Setting
Application	SH+DHW-1-Vlv
SH Operating Mode	Constant Setpoint, Outdoor Air Reset or Remote Setpoint
DHW Operating Mode	Constant Setpoint
DHW Setup	2 Port Tank
DHW Pump Control Type	Constant On
CASCADE CONFIGURATION-Hdr Temp Sensor	Direct
CASCADE CONFIGURATION-Outdoor Air Temp Sensor <i>(If SH Operating Mode=Outdoor Air Reset)</i>	Direct
VALVE CONFIGURATION-Select Output	Cascade Valve
VALVE CONFIGURATION-Valve Feedback	Enabled
Unit Address for B-1 <i>(in this piping diagram)</i>	1
Unit Address for B-2 <i>(in this piping diagram)</i>	2
Unit Address for B-3 <i>(in this piping diagram)</i>	3
Unit 1 Designation	SH
Unit 2 Designation	SH
Unit 3 Designation	Swing
Default Swing Boiler Load	Swing Default DHW

**Legend:**

S-1 = Header Sensor  
 S-2 = Outdoor Air Sensor  
 S-3 = Return Sensor  
 P-1a, P-1b = System Pump(s)  
 V-1, V-2, V-3 = Sequencing Valves  
 P-2 = Combination System Pump  
 DHW = DHW Boiler Sensor  
 SV = Swing Valve

DHW = DHW Boiler Sensor  
 SV = Swing Valve

Load	Swing Valve	Swing Boiler B-3 DHW Priority	Combination System Pump
SH ≤ 100% DHW ≤ 100%	Close	DHW	ON
SH ≤ 100% DHW = None	Close	Standby	ON
SH = 100% DHW = None	Open	Space Heating	ON

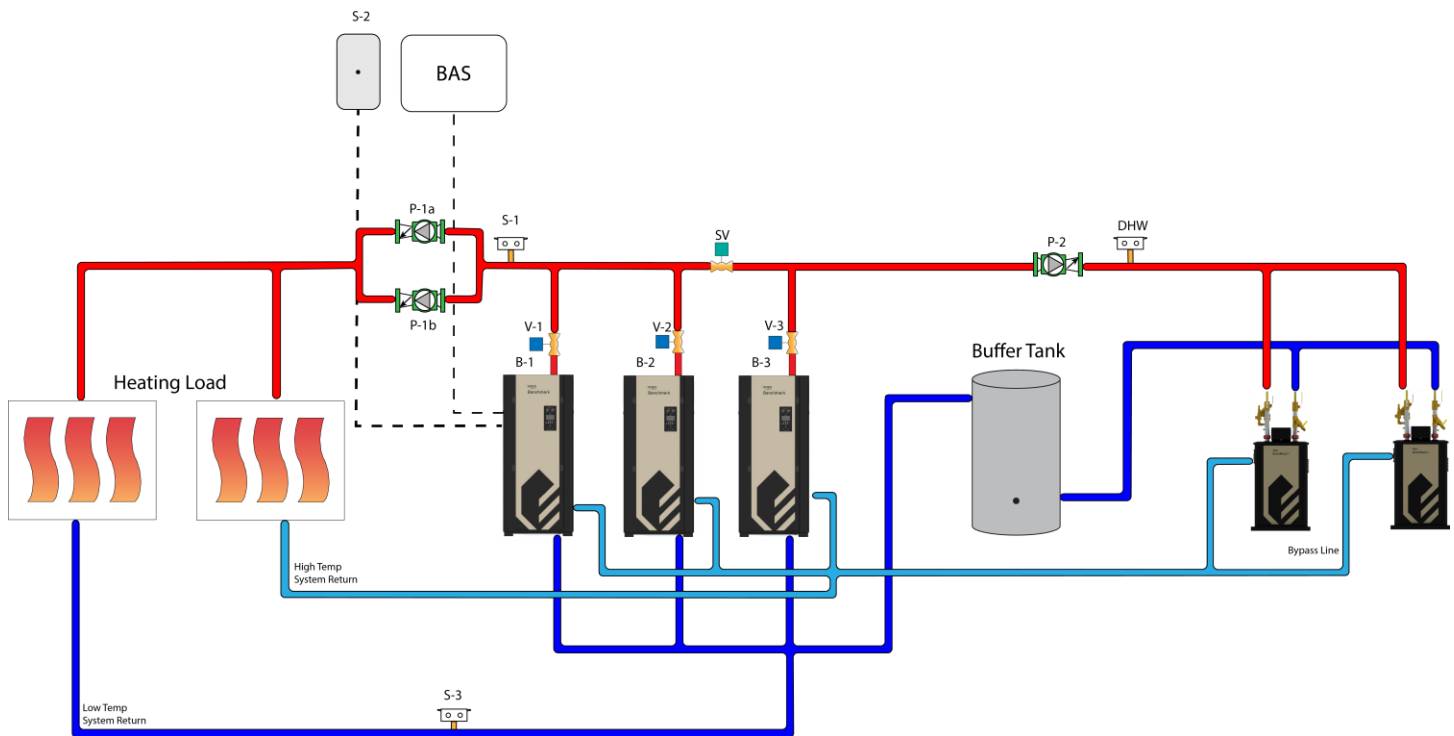

**Diagram 4-3a: Combination Plant with One Swing Valve and 2-Port Buffer Tank Piping**

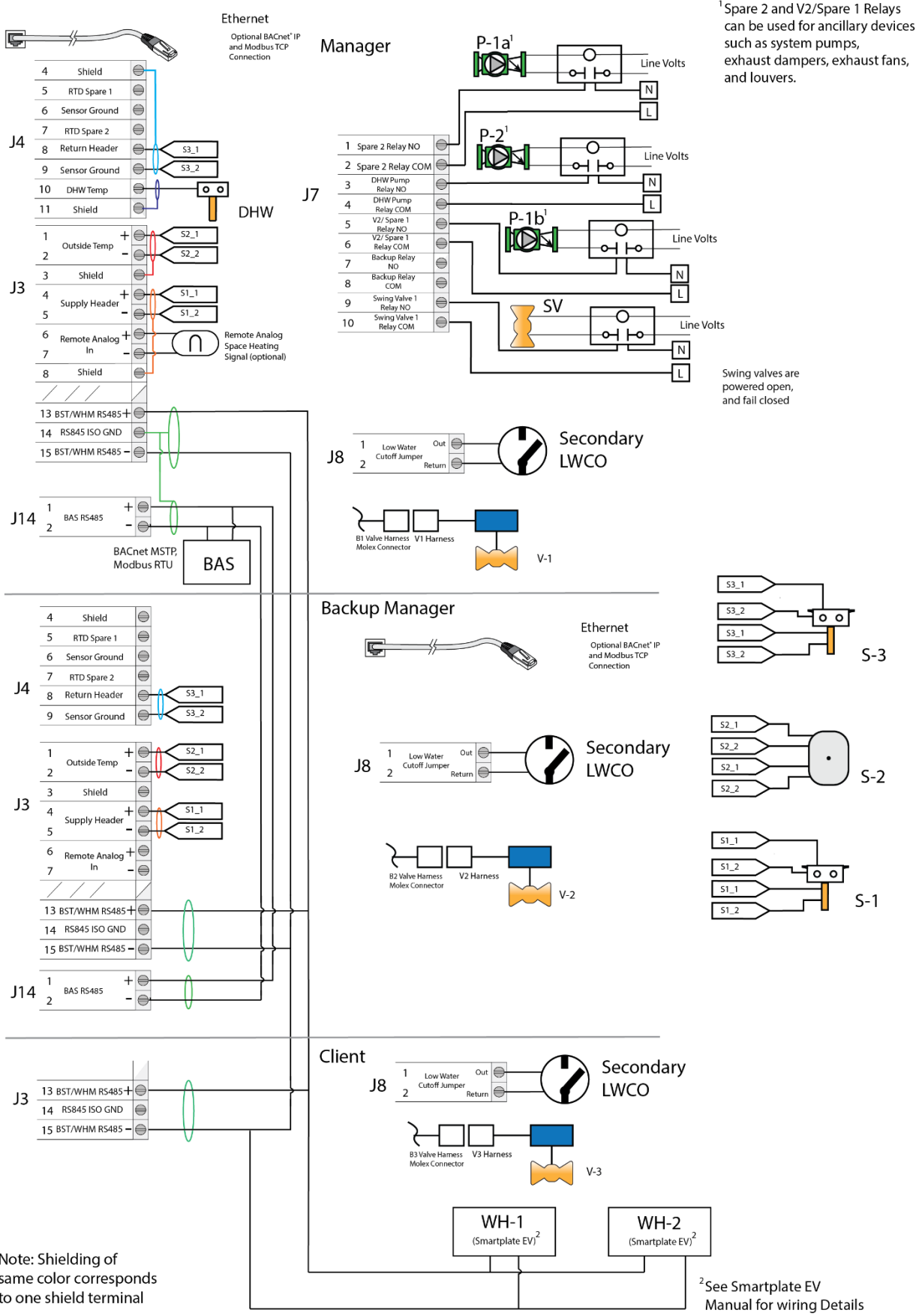

**Diagram 4-3b: Combination Plant with One Swing Valve and 2-Port Buffer Tank Wiring**

### 4.4 Combination Plant with One Swing Valve and 4-port Buffer Tank

**Application Description & Features:** Combination boiler plant serves space heating and domestic hot water generation through AERCO SmartPlate EV water heaters. Benchmark boilers are operated via Boiler Sequencing Technology (BST) to provide space heating. Space heating supply temperature is maintained as constant setpoint, via outdoor air reset or from remote setpoint command (from building automation system or via remote analog signal). Swing boiler is assigned to serve the water heater by default and assist in space heating when domestic hot water load is satisfied. Swing valve separates boilers serving domestic hot water from space heating. Combination system pump is controlled by the DHW temperature sensor; DHW pump runs continuously to provide boiler water to the water heaters. 4-port buffer tank is utilized to dampen out fast domestic load transitions and minimize boiler cycling. Application utilizes AERCO supplied header sensor, sequencing valves and outdoor air sensor; return header sensor is optional.

- The Edge Controller sequences the boiler plant to obtain maximum system efficiency by running as many boilers as available, each operating at its most efficient firing rate.
- The swing boiler serves the domestic hot water by default and may be used to implement "N+1" sizing method for space heating.
- Sequencing valves isolate standby boilers from the system, reducing the system's minimum flow requirement.
- Edge controller supports integration with BAS via BACnet MSTP, BACnet IP, Modbus RTU and Modbus TCP.

**Essential System Settings:**

Parameter	Setting
Application	SH+DHW-1-Vlv
SH Operating Mode	Constant Setpoint, Outdoor Air Reset or Remote Setpoint
DHW Operating Mode	Constant Setpoint
DHW Setup	4 Port Tank
DHW Pump Control Type	Controlled
CASCADE CONFIGURATION-Hdr Temp Sensor	Direct
CASCADE CONFIGURATION-Outdoor Air Temp Sensor <i>(If SH Operating Mode=Outdoor Air Reset)</i>	Direct
VALVE CONFIGURATION-Select Output	Cascade Valve
VALVE CONFIGURATION-Valve Feedback	Enabled
Unit Address for B-1 <i>(in this piping diagram)</i>	1
Unit Address for B-2 <i>(in this piping diagram)</i>	2
Unit Address for B-3 <i>(in this piping diagram)</i>	3
Unit 1 Designation	SH
Unit 2 Designation	SH
Unit 3 Designation	Swing
Default Swing Boiler Load	Swing Default SH

# Benchmark Series Boilers Application Design Guide

## Legend:

S-1 = Header Sensor

S-2 = Outdoor Air Sensor

S-3 = Return Sensor

P-1a, P-1b = System Pump(s)

V-1, V-2, V-3 = Sequencing Valves

P-2 = Combination System Pump

P-3 = DHW Pump

DHW = DHW Boiler Sensor

SV = Swing Valve

Load	Swing Valve	Swing Boiler B-3 DHW Priority	Combination System Pump
SH ≤ 100% DHW ≤ 100%	Close	DHW	ON
SH ≤ 100% DHW = None	Close	Standby	OFF
SH = 100% DHW = None	Open	Space Heating	OFF

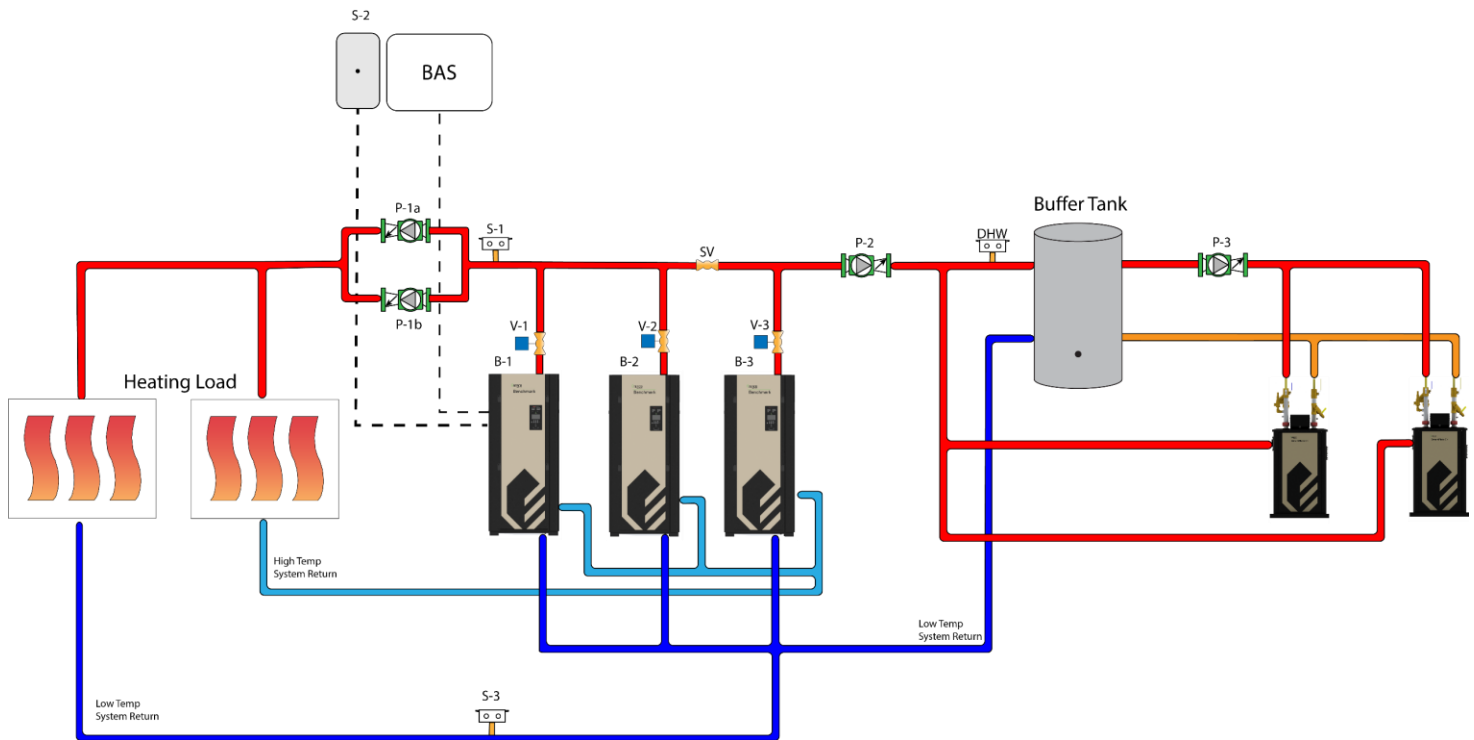

**Diagram 4-4a: Combination Plant with One Swing Valve and 4-Port Buffer Tank Piping**

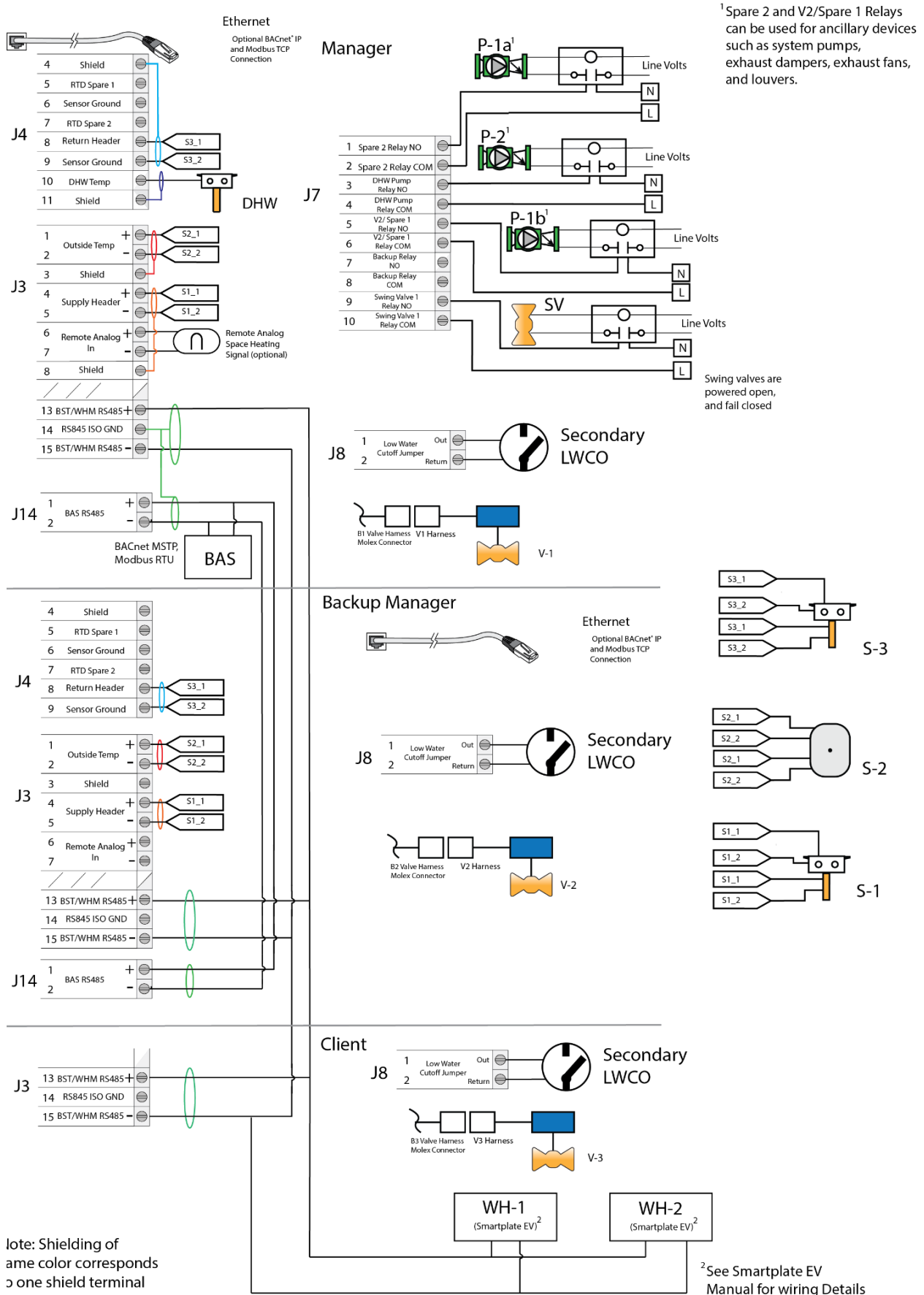

**Diagram 4-4b: Combination Plant with One Swing Valve and 4-Port Buffer Tank Wiring**

Note: Shielding of same color corresponds to one shield terminal

**4.5 Combination Plant with 1 Swing Valve + Indirect Storage Tank Water Heater**

**Application Description & Features:** Combination plant consists of AERCO Benchmark boilers, operated via Boiler Sequencing Technology (BST) to provide space heating. Supply temperature is maintained via constant setpoint, outdoor air reset or remote setpoint command (from building automation system or remote analog signal). Domestic hot water is generated using an indirect storage tank water heater. Swing boiler is assigned to serve the water heater by default and assist in space heating when domestic hot water load is satisfied. Swing valve separates boilers serving domestic hot water from space heating. DHW boiler pump is controlled by aquastat to provide boiler water to the indirect storage tank water heater. Application utilizes AERCO supplied header sensor, sequencing valves and outdoor air sensor; return header sensor is optional.

- The Edge controller sequences the boiler plant to obtain maximum system efficiency by running as many boilers as available, each operating at its most efficient firing rate.
- The swing boiler assists in space heating when domestic hot water load is satisfied.
- Sequencing valves isolate standby boilers from the system, reducing the system’s minimum flow requirement.
- Edge[iii] controller supports integration with BAS via BACnet MSTP, BACnet IP, Modbus RTU and Modbus TCP.

**Essential System Settings:**

Parameter	Setting
Application	SH+DHW-1-Vlv
SH Operating Mode	Constant Setpoint, Outdoor Air Reset or Remote Setpoint
DHW Operating Mode	Constant Setpoint
DHW Setup	Indirect Tank
DHW Pump Control Type	Controlled
DHW Aquastat Enable	Enabled
DHW Temp Sensor	Off
CASCADE CONFIGURATION-Hdr Temp Sensor	Direct
CASCADE CONFIGURATION-Outdoor Air Temp Sensor (If SH Operating Mode=Outdoor Air Reset)	Direct
VALVE CONFIGURATION-Select Output	Cascade Valve
Unit Address for B-1 (in this piping diagram)	1
Unit Address for B-2 (in this piping diagram)	2
Unit Address for B-3 (in this piping diagram)	3
Unit 1 Designation	SH
Unit 2 Designation	SH
Unit 3 Designation	Swing
Default Swing Boiler Load	Swing Default DHW

**Legend:**

S-1 = Header Sensor  
 S-2 = Outdoor Air Sensor  
 S-3 = Return Sensor  
 P-1a, P-1b = System Pump(s)  
 V-1, V-2, V-3 = Sequencing Valves  
 P-2 = Combination System Pump  
 SV = Swing Valve

Load	Swing Valve	Swing Boiler B-3 DHW Priority	Combination System Pump
SH ≤ 100% DHW ≤ 100%	Close	DHW	ON
SH ≤ 100% DHW = None	Close	Standby	OFF
SH = 100% DHW = None	Open	Space Heating	OFF

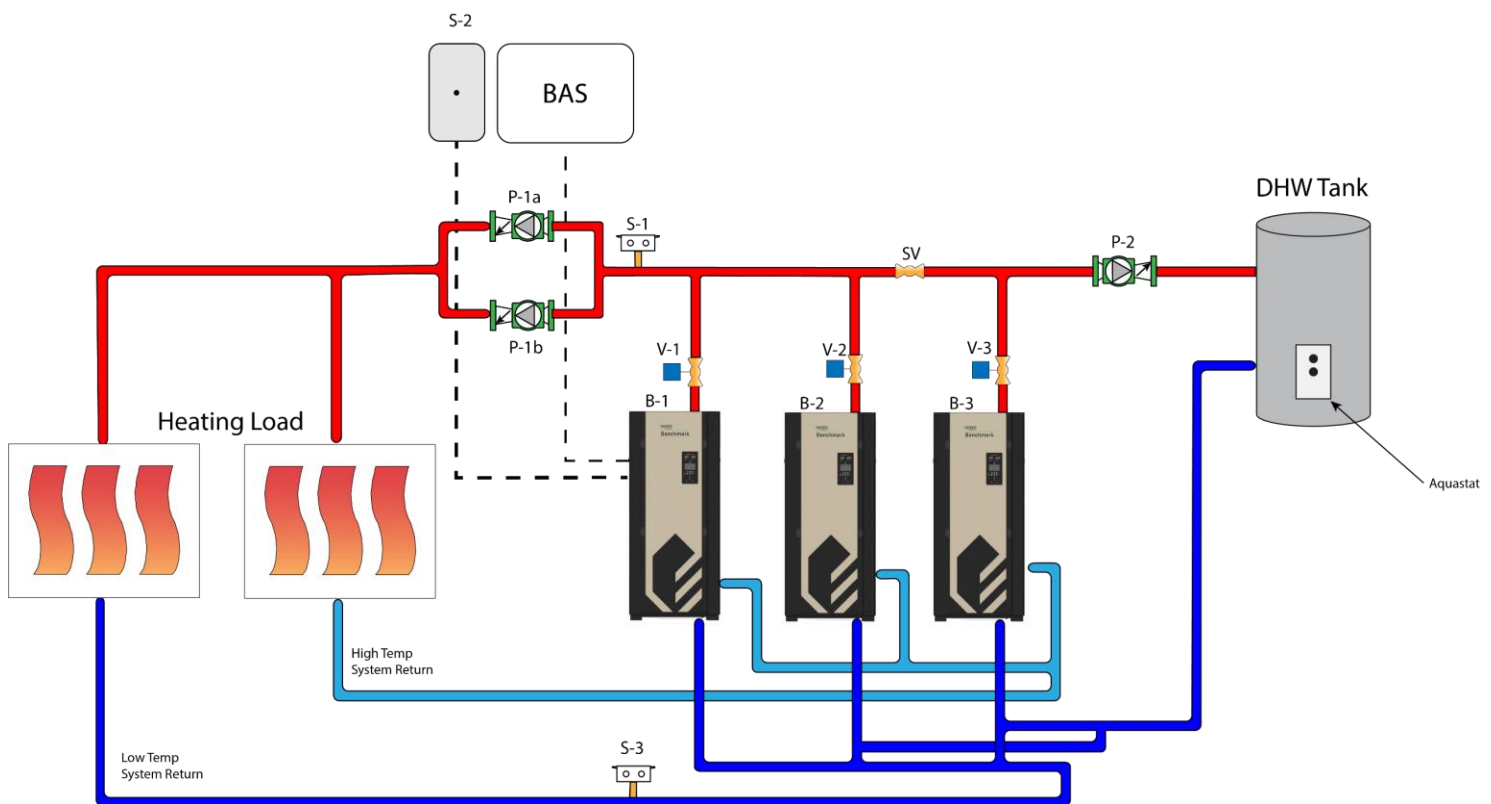

**Diagram 4-5a: Combination Plant with One Swing Valve and Domestic Hot Water System Piping**

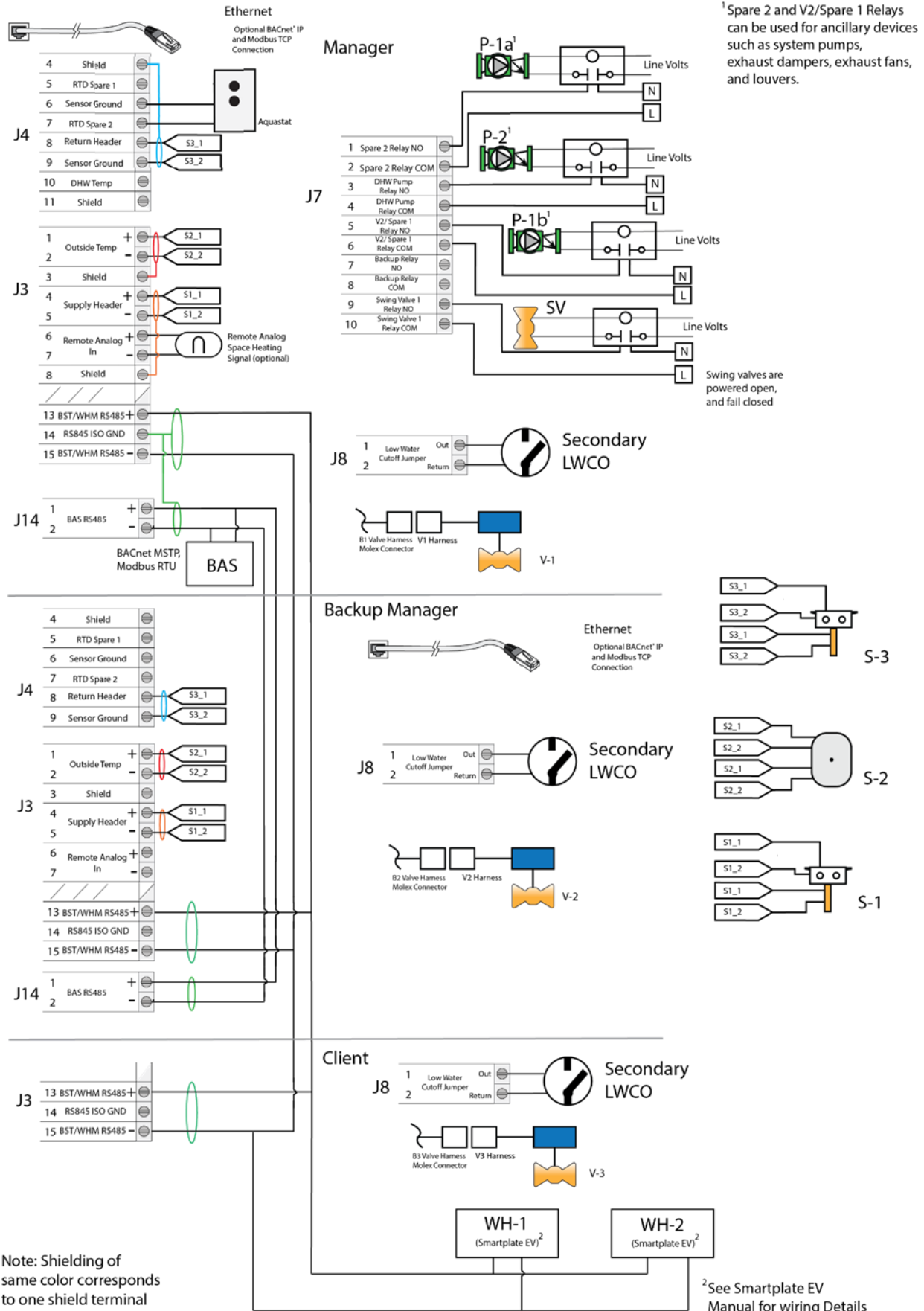

**Diagram 4-5b: Combination Plant with One Swing Valve and Domestic Hot Water System Wiring**

**4.6 Combination Plant with Two Swing Valves and 2-port Buffer Tank**

**Application Description & Features:** Combination plant consists of AERCO Benchmark boilers, operated via Boiler Sequencing Technology (BST) to provide space heating. Supply temperature is maintained via constant setpoint, outdoor air reset or remote setpoint command (from building automation system or remote analog signal). Domestic hot water is generated using AERCO SmartPlate EV water heaters; DHW boiler sensor is used for controlling domestic boiler loop temperature. A boiler is dedicated to serve the domestic hot water load. Swing boiler is assigned to serve space heating by default and assist the domestic hot water load. Swing valves separate the heating, swing and domestic boilers. DHW boiler pump runs continuously to provide boiler water to the water heaters. 2-port buffer tank is utilized to dampen out fast domestic load transitions and minimize boiler cycling. Application utilizes AERCO supplied header sensor, sequencing valves and outdoor air sensor; return header sensor is optional.

- The Edge Controller sequences the boiler plant to obtain maximum system efficiency by running as many boilers as available, each operating at its most efficient firing rate.
- The swing boiler provides redundancy to domestic hot water boiler
- Sequencing valves isolate standby boilers from the system, reducing the system’s minimum flow requirement.
- Edge[iii] controller supports integration with BAS via BACnet MSTP, BACnet IP, Modbus RTU and Modbus TCP.

**Essential System Settings:**

Parameter	Setting
Application	SH+DHW-2-Vlv
SH Operating Mode	Constant Setpoint, Outdoor Air Reset or Remote Setpoint
DHW Operating Mode	Constant Setpoint
DHW Setup	2 Port Tank
DHW Pump Control Type	Constant On
CASCADE CONFIGURATION-Hdr Temp Sensor	Direct
CASCADE CONFIGURATION-Outdoor Air Temp Sensor <i>(If SH Operating Mode=Outdoor Air Reset)</i>	Direct
VALVE CONFIGURATION-Select Output	Cascade Valve
VALVE CONFIGURATION-Valve Feedback	Enabled
Unit Address for B-1 <i>(in this piping diagram)</i>	1
Unit Address for B-2 <i>(in this piping diagram)</i>	2
Unit Address for B-3 <i>(in this piping diagram)</i>	3
Unit 1 Designation	SH
Unit 2 Designation	Swing
Unit 3 Designation	DHW
Default Swing Boiler Load	Swing Default SH

**Legend:**

S-1 = Header Sensor  
 S-2 = Outdoor Air Sensor  
 S-3 = Return Sensor  
 P-1a, P-1b = System Pump(s)  
 V-1, V-2, V-3 = Sequencing Valves  
 P-2 = Combination System Pump  
 DHW = DHW Boiler Sensor  
 SV-1 = Swing Valve #1  
 SV-2 = Swing Valve #2

Load	Swing Valve #1	Swing Valve #2	Swing Boiler	DHW Boiler	Combination System Pump
SH ≤ 100% DHW ≤ 100%	Close	Open	Space Heating	DHW	ON
SH < 100% DHW = None	Close	Open	Space Heating	Standby	ON
SH = 100% DHW = None	Open	Open	Space Heating	Space Heating	ON
SH < 100% DHW > 90%, (10 min)	Open	Close	DHW	DHW	ON

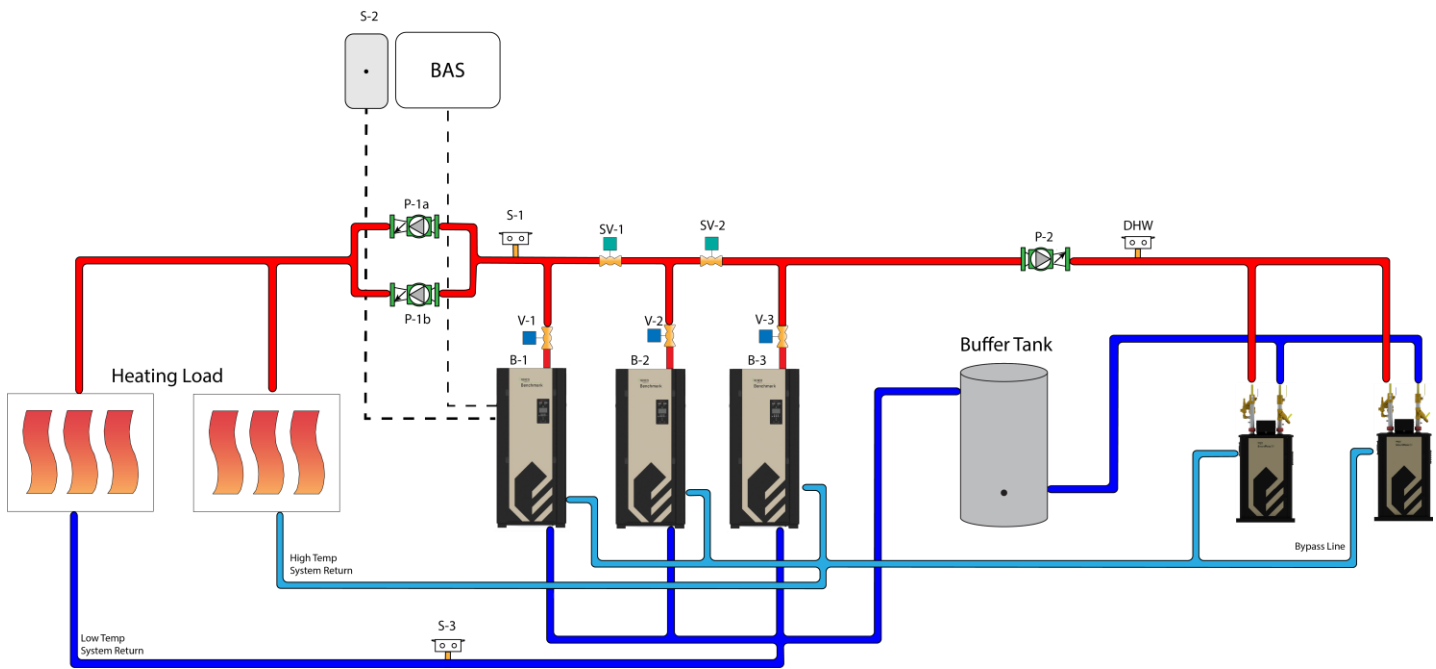

**Diagram 4-6a: Combination Plant with Two Swing Valves and 2-Port Buffer Tank Piping**

# Benchmark Series Boilers Application Design Guide

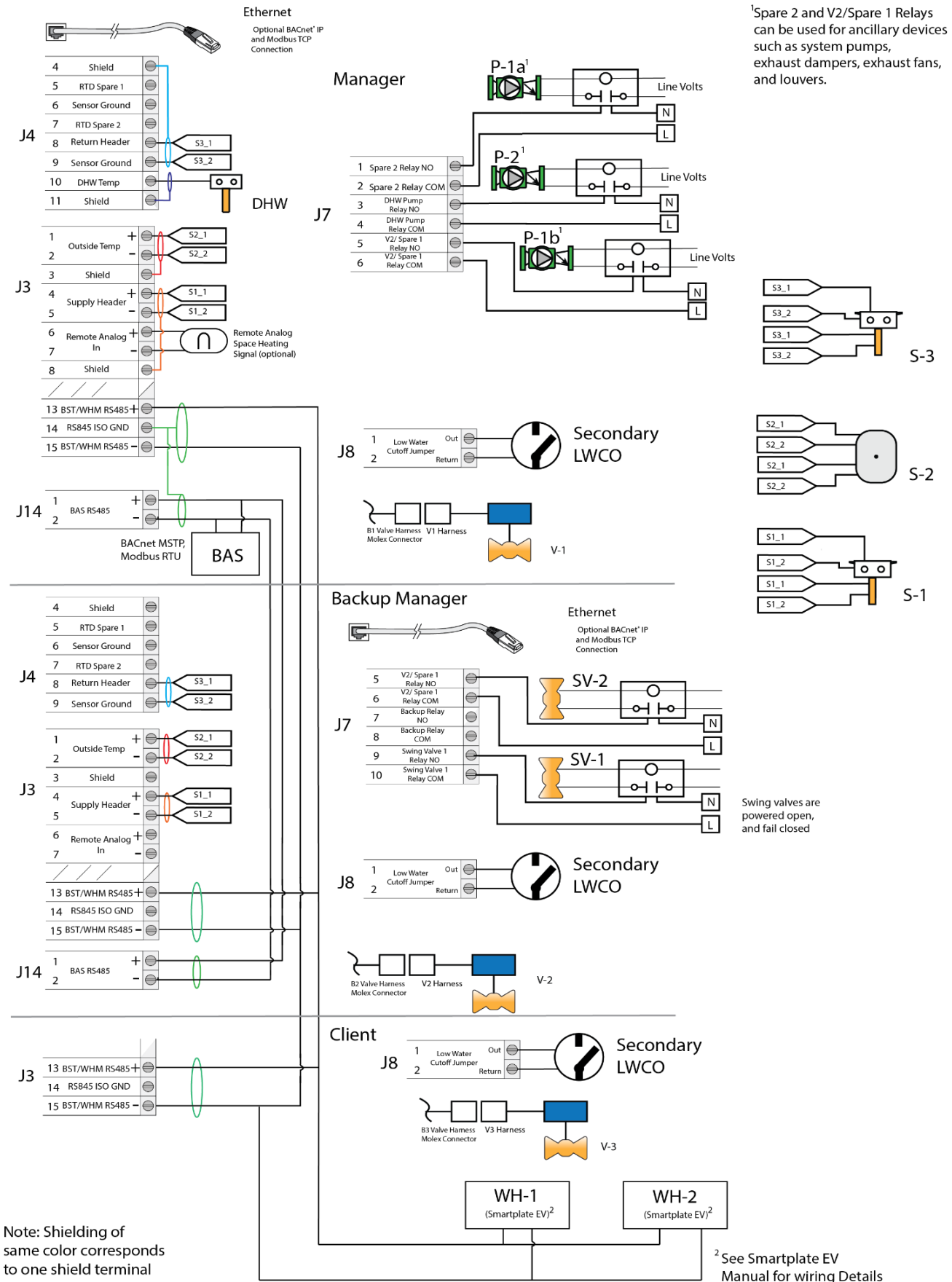

Note: Shielding of same color corresponds to one shield terminal

**Diagram 4-6b: Combination Plant with Two Swing Valves and 2-Port Buffer Tank Wiring**

**4.7 Combination Plant with Two Swing Valves and 4-port Buffer Tank**

**Application Description & Features:** Combination plant consists of AERCO Benchmark boilers, operated via Boiler Sequencing Technology (BST) to provide space heating. Supply temperature is maintained via constant setpoint, outdoor air reset or remote setpoint command (from building automation system or remote analog signal). Domestic hot water is generated using AERCO SmartPlate EV water heaters. A boiler is dedicated to serve the domestic hot water load. Swing boiler is assigned to serve space heating by default and assist the domestic hot water load. Swing valves separate the heating, swing and domestic boilers. DHW boiler sensor is used for controlling domestic boiler loop temperature and the combination system pump. DHW boiler pump is enabled externally and runs continuously to provide boiler water to the water heaters. 4-port buffer tank is utilized to dampen out fast domestic load transitions and minimize boiler cycling. Application utilizes AERCO supplied header sensor, sequencing valves and outdoor air sensor; return header sensor is optional.

- The Edge Controller sequences the boiler plant to obtain maximum system efficiency by running as many boilers as available, each operating at its most efficient firing rate.
- The swing boiler provides redundancy to domestic hot water boiler.
- Sequencing valves isolate standby boilers from the system, reducing the system’s minimum flow requirement.
- Edge[iii] controller supports integration with BAS via BACnet MSTP, BACnet IP, Modbus RTU and Modbus TCP.

**Essential System Settings:**

Parameter	Setting
Application	SH+DHW-2-Vlv
SH Operating Mode	Constant Setpoint, Outdoor Air Reset or Remote Setpoint
DHW Operating Mode	Constant Setpoint
DHW Setup	4 Port Tank
DHW Pump Control Type	Controlled
CASCADE CONFIGURATION-Hdr Temp Sensor	Direct
CASCADE CONFIGURATION-Outdoor Air Temp Sensor <i>(If SH Operating Mode=Outdoor Air Reset)</i>	Direct
VALVE CONFIGURATION-Select Output	Cascade Valve
VALVE CONFIGURATION-Valve Feedback	Enabled
Unit Address for B-1 <i>(in this piping diagram)</i>	1
Unit Address for B-2 <i>(in this piping diagram)</i>	2
Unit Address for B-3 <i>(in this piping diagram)</i>	3
Unit 1 Designation	SH
Unit 2 Designation	Swing
Unit 3 Designation	DHW
Default Swing Boiler Load	Swing Default SH

Load	Swing Valve #1	Swing Valve #2	Swing Boiler	DHW Boiler	Combination System Pump
SH ≤ 100% DHW ≤ 100%	Close	Open	Space Heating	DHW	ON
SH < 100% DHW = None	Close	Open	Space Heating	Standby	OFF
SH = 100% DHW = None	Open	Open	Space Heating	Space Heating	OFF
SH < 100% DHW > 90%, (10 min)	Open	Close	DHW	DHW	ON

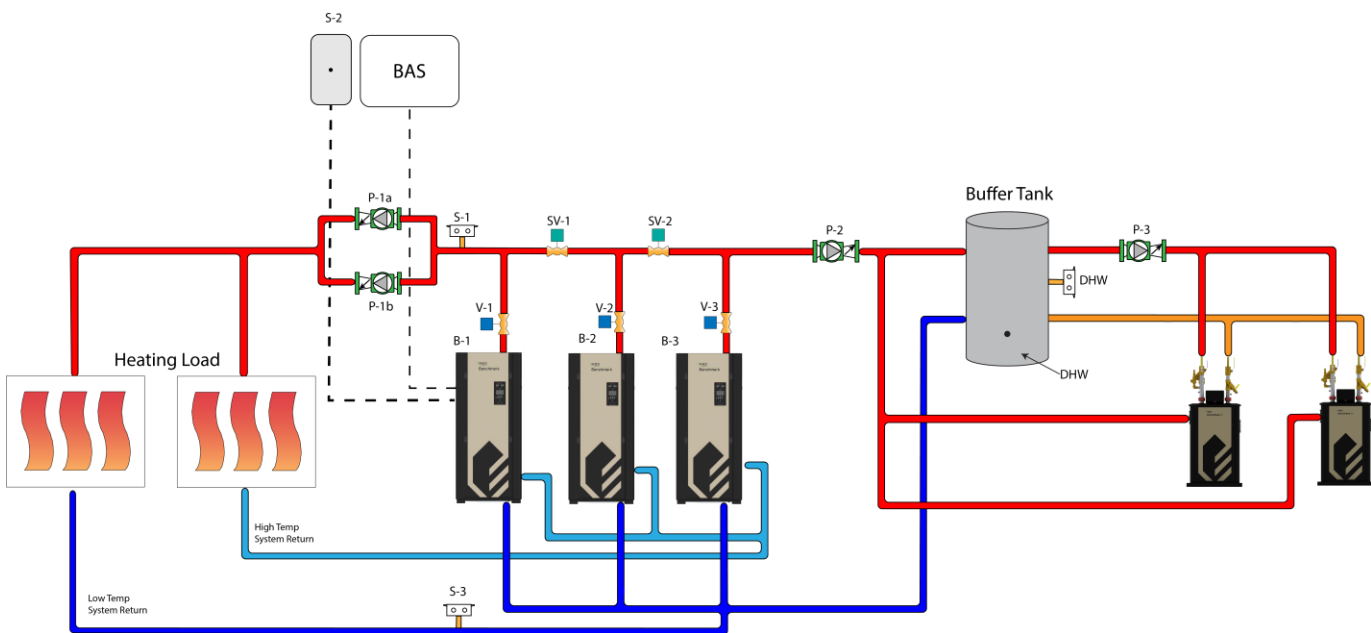

**Diagram 4-7a: Combination Plant with Two Swing Valves and 4-Port Buffer Tank Piping**

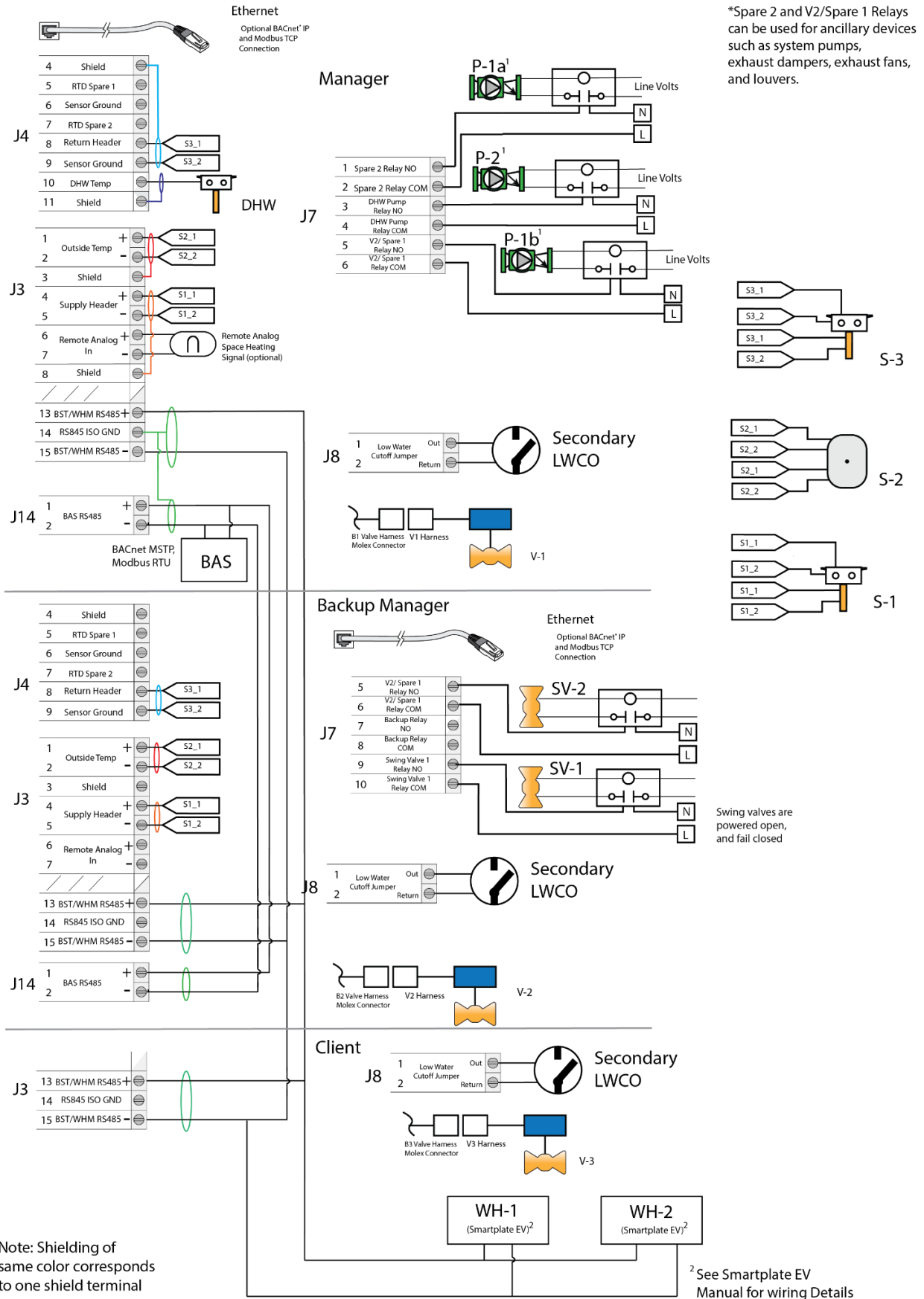

Note: Shielding of same color corresponds to one shield terminal

**Diagram 4-7b: Combination Plant with Two Swing Valves and 4-Port Buffer Tank Wiring**

### 4.8 Combination Plant with Two Swing Valves and 4-port Buffer Tank (Primary-Secondary Piping)

**Application Description & Features:** Boiler plant is piped in primary-secondary method with individual boiler pumps. Combination boiler plant serves space heating and domestic hot water generation through AERCO SmartPlate EV water heaters. Benchmark boilers are operated via Boiler Sequencing Technology (BST) to provide space heating. Space heating supply temperature is maintained via constant setpoint, outdoor air reset or from remote setpoint command (from building automation system or remote analog signal). A boiler is dedicated to serve the domestic hot water load. Swing boiler is assigned to serve space heating and assist the domestic hot water load. Swing valves separate the heating, swing and domestic boilers. DHW boiler pump runs continuously to provide boiler water to the water heaters. 4-port buffer tank is utilized to dampen out fast domestic load transitions and minimize boiler cycling. Application utilizes AERCO supplied header sensor, sequencing valves and outdoor air sensor; return header sensor is optional (required if VSP Pump Mode=Return Temp).

- The AERCO Edge Controller sequences the boiler plant for maximum system efficiency by running as many boilers as available, each operating at its most efficient firing rate.
- The swing boiler provides redundancy to domestic hot water boiler.
- Use of variable speed boiler pumps prevents hot water recirculation at the low loss header, resulting to increased efficiency.
- Edge[ii] controller supports integration with BAS via BACnet MSTP, BACnet IP, Modbus RTU and Modbus TCP.

**Note:** For more information on variable speed pump control modes, consult Edge [ii] Controls Manual OMM-0139.

**Essential System Settings:**

Parameter	Setting
Application	SH+DHW-2-Vlv
SH Operating Mode	Constant Setpoint, Outdoor Air Reset or Remote Setpoint
DHW Operating Mode	Constant Setpoint
DHW Setup	4 Port Tank
DHW Pump Control Type	Constant On
CASCADE CONFIGURATION-Hdr Temp Sensor	Direct
CASCADE CONFIGURATION-Outdoor Air Temp Sensor <i>(If SH Operating Mode=Outdoor Air Reset)</i>	Direct
VSP Pump Mode	Return Temp (Return Sensor Required) or Fire Rate
VSP Piping Configuration	1 Pump Per Blr
Unit Address for B-1 <i>(in this piping diagram)</i>	1
Unit Address for B-2 <i>(in this piping diagram)</i>	2
Unit Address for B-3 <i>(in this piping diagram)</i>	3
Unit 1 Designation	SH
Unit 2 Designation	Swing
Unit 3 Designation	DHW
Default Swing Boiler Load	Swing Default SH

**Legend:**  
 S-1 = Header Sensor  
 S-2 = Outdoor Air Sensor  
 S-3 = Return Sensor  
 P-1, P-2, P-3 = Boiler Pumps  
 V-1, V-2, V-3 = Sequencing Valves  
 P-4 = DHW Pump  
 DHW = DHW Boiler Sensor  
 SV-1 = Swing Valve #1  
 SV-2 = Swing Valve #2

Load	Swing Valve #1	Swing Valve #2	Swing Boiler	DHW Boiler	DHW Pump
SH ≤ 100% DHW ≤ 100%	Close	Open	Space Heating	DHW	ON
SH < 100% DHW = None	Close	Open	Space Heating	Standby	ON
SH = 100% DHW = None	Open	Open	Space Heating	Space Heating	ON
SH < 100% DHW > 90%, (10 min)	Open	Close	DHW	DHW	ON

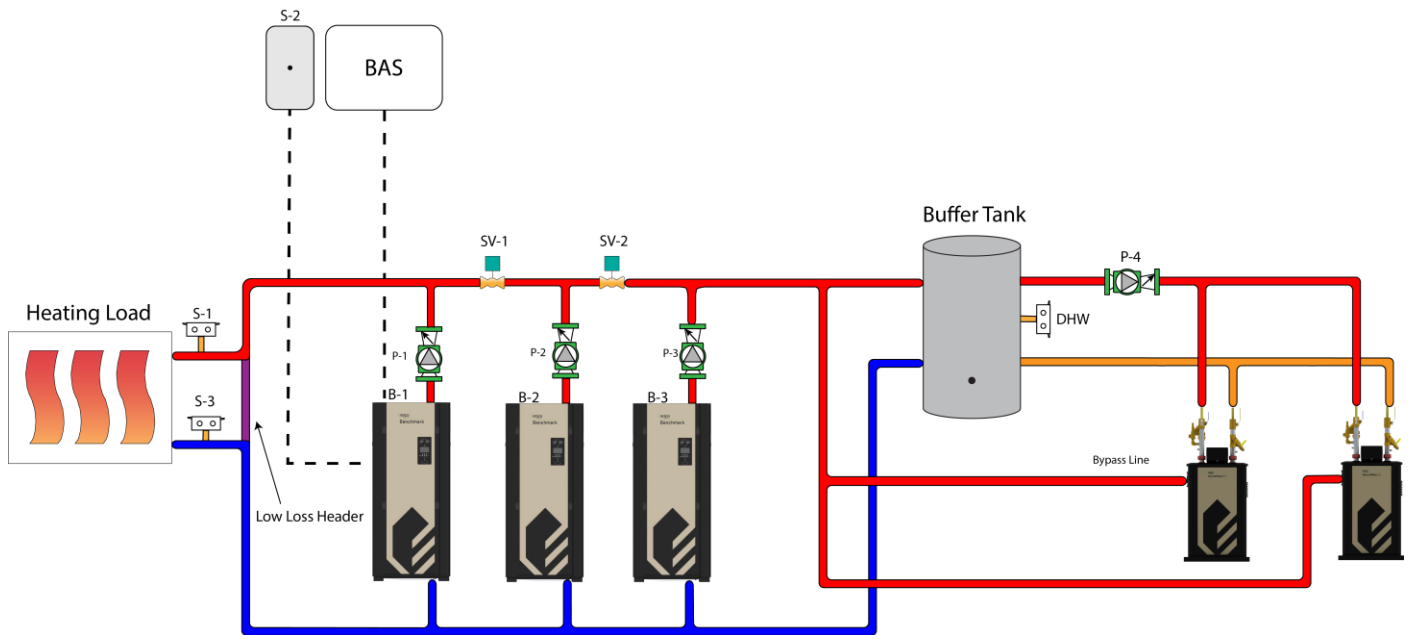

**Diagram 4-8a: Combination Plant with Two Swing Valves and 4-Port Buffer Tank (Primary-Secondary) Piping**

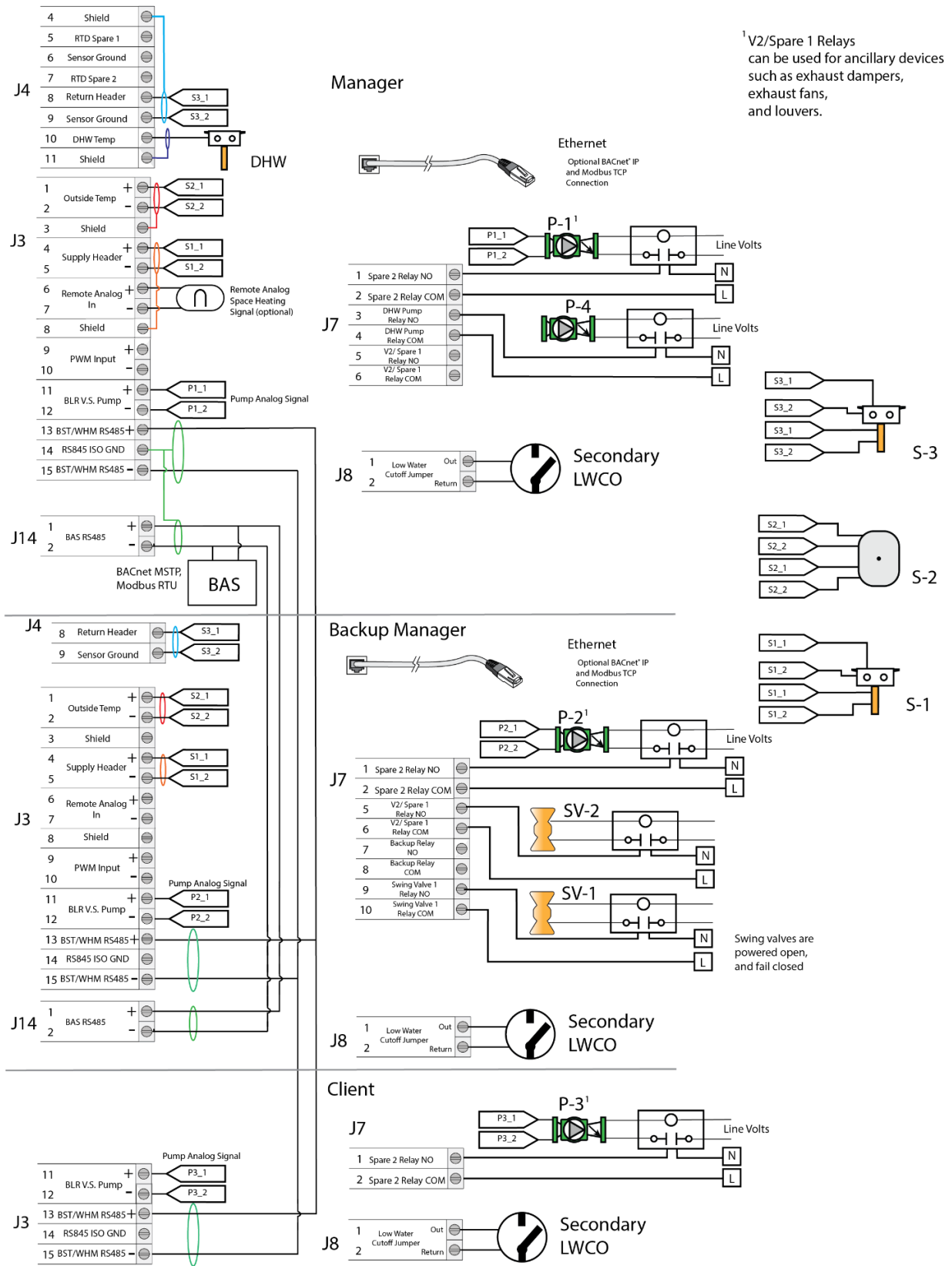

Note: Shielding of same color corresponds to one shield terminal

**Diagram 4-8b: Combination Plant with Two Swing Valves and 4-Port Buffer Tank (Primary-Secondary) Wiring**

**4.9 Combination Plant with 2 Swing Valves + Domestic Hot Water Tank**

**Application Description & Features:** Combination plant consists of AERCO Benchmark boilers, operated via Boiler Sequencing Technology (BST) to provide space heating. Supply temperature is maintained via constant setpoint, outdoor air reset or remote setpoint command (from building automation system or remote analog signal). Domestic hot water is generated using an indirect storage tank water heater. A boiler is dedicated to serve the domestic hot water load. Swing boiler is assigned to serve space heating by default and assist the domestic hot water load. Swing valves separate the heating, swing and domestic boilers. DHW boiler pump is controlled by an aquastat to provide boiler water to the indirect storage tank water heater. Application utilizes AERCO supplied header sensor, sequencing valves and outdoor air sensor; return header sensor is optional.

- The AERCO Edge Controller sequences the boiler plant for maximum system efficiency by running as many boilers as available, each operating at its most efficient firing rate.
- The swing boiler provides redundancy to domestic hot water boiler.
- Sequencing valves isolate standby boilers from the system, reducing the system’s minimum flow requirement.
- Edge[iii] controller supports integration with BAS via BACnet MSTP, BACnet IP, Modbus RTU and Modbus TCP.

**Essential System Settings:**

Parameter	Setting
Application	SH+DHW-2-Vlv
SH Operating Mode	Constant Setpoint, Outdoor Air Reset or Remote Setpoint
DHW Operating Mode	Constant Setpoint
DHW Setup	Indirect Tank
DHW Pump Control Type	Controlled
DHW Aquastat Enable	Enabled
DHW Temp Sensor	Off
CASCADE CONFIGURATION-Hdr Temp Sensor	Direct
CASCADE CONFIGURATION-Outdoor Air Temp Sensor <i>(If SH Operating Mode=Outdoor Air Reset)</i>	Direct
VALVE CONFIGURATION-Select Output	Cascade Valve
Unit Address for B-1 (in this piping diagram)	1
Unit Address for B-2 (in this piping diagram)	2
Unit Address for B-3 (in this piping diagram)	3
Unit 1 Designation	SH
Unit 2 Designation	Swing
Unit 3 Designation	DHW
Default Swing Boiler Load	Swing Default SH

**Legend:**

S-1 = Header Sensor

S-2 = Outdoor Air Sensor

S-3 = Return Sensor

P-1a, P-1b = System Pump(s)

V-1, V-2, V-3 = Sequencing Valves

P-2 = Combination System Pump

SV-1 = Swing Valve #1

SV-2 = Swing Valve #2

Load	Swing Valve #1	Swing Valve #2	Swing Boiler	DHW Boiler	Combination System Pump
SH ≤ 100% DHW ≤ 100%	Close	Open	Space Heating	DHW	ON
SH < 100% DHW = None	Close	Open	Space Heating	Standby	OFF
SH = 100% DHW = None	Open	Open	Space Heating	Space Heating	OFF
SH < 100% DHW > 90%, (10 min)	Open	Close	DHW	DHW	ON

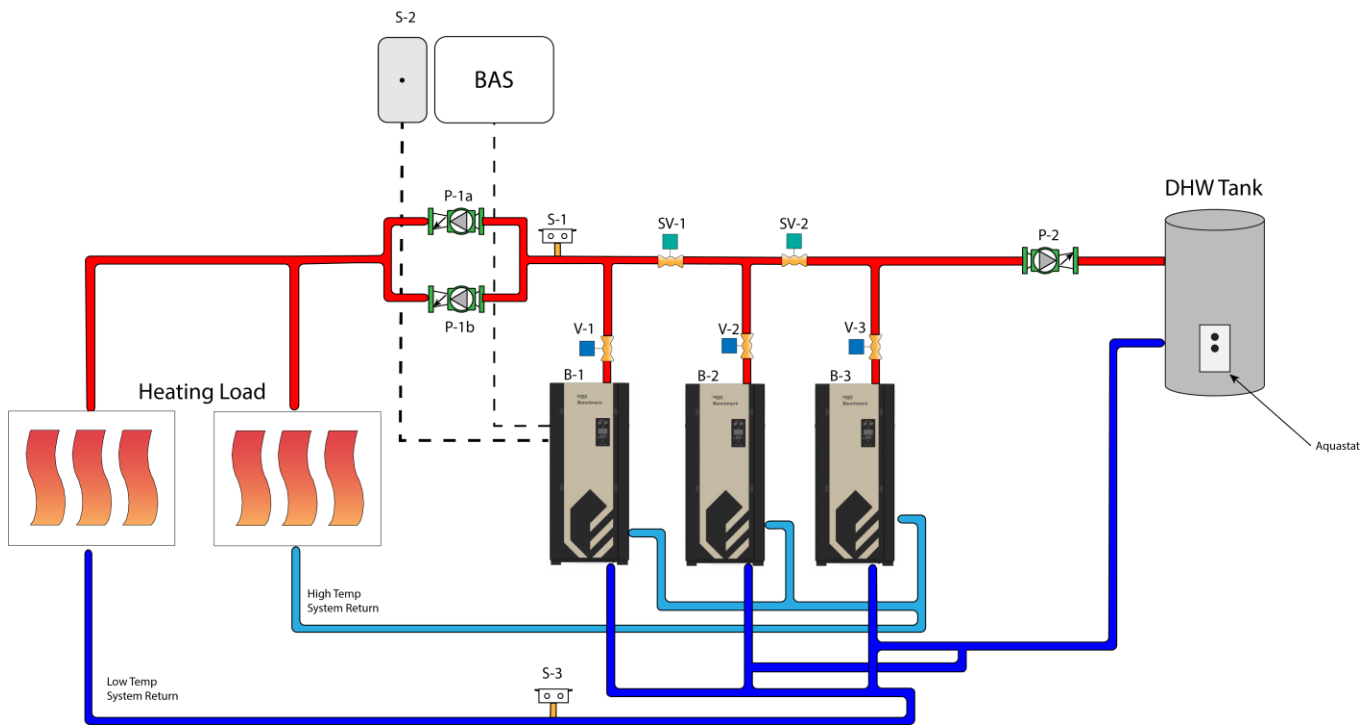

**Diagram 4-9a: Combination Plant with Two Swing Valves and Domestic Hot Water Tank Piping**

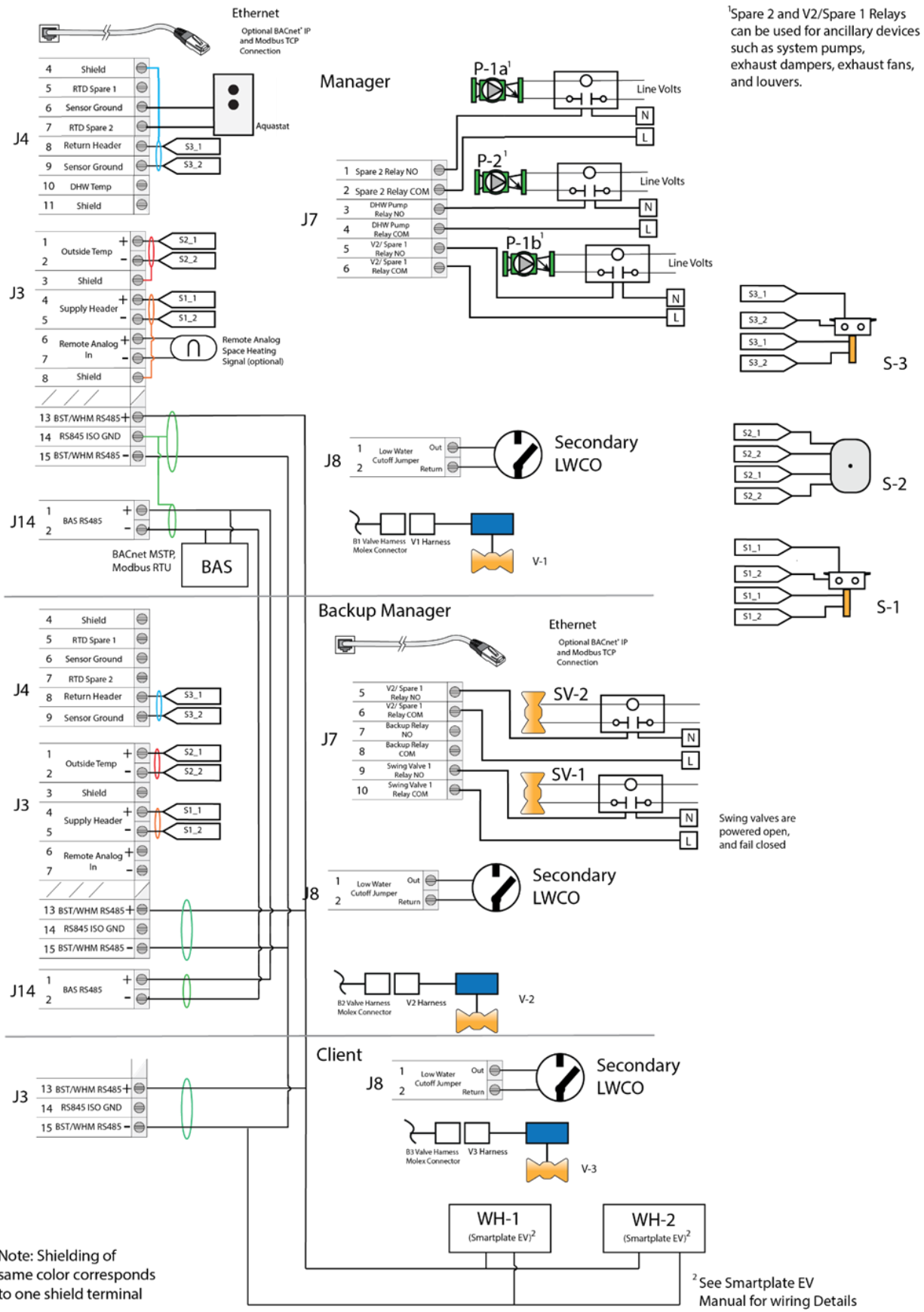

**Diagram 4-9b: Combination Plant with Two Swing Valves and Domestic Hot Water Tank Wiring**

**4.10 Combination System w/ 2-Port Buffer Tank & Domestic Summer Pump Mode**

**Application Description & Features:** AERCO Benchmark boilers are operated via Boiler Sequencing Technology (BST) to provide space heating and domestic hot water generation through AERCO SmartPlate EV water heaters. Space heating supply temperature is maintained as constant setpoint, via outdoor air reset or from remote setpoint command (from building automation system or via remote analog signal). DHW boiler/summer pump runs continuously to provide boiler water to the water heaters. 2-port buffer tank is utilized to dampen out fast domestic load transitions and minimize boiler cycling. Application utilizes AERCO supplied header sensor, sequencing valves and outdoor air sensor; return header sensor is optional.

- The AERCO Edge Controller sequences the boiler plant for maximum system efficiency by running as many boilers as available, each operating at its most efficient firing rate.
- Sequencing valves isolate standby boilers from the system, reducing the system’s minimum flow requirement.
- Edge[iii] controller supports integration with BAS via BACnet MSTP, BACnet IP, Modbus RTU and Modbus TCP.

**Essential System Settings:**

Parameter	Setting
Application	SH+DHW-Stpt Prty
SH Operating Mode	Constant Setpoint, Outdoor Air Reset or Remote Setpoint
DHW Operating Mode	Constant Setpoint
DHW Pump Control Type	Constant On
CASCADE CONFIGURATION-Hdr Temp Sensor	Direct
CASCADE CONFIGURATION-Outdoor Air Temp Sensor <i>(If SH Operating Mode=Outdoor Air Reset)</i>	Direct
VALVE CONFIGURATION-Select Output	Cascade Valve
VALVE CONFIGURATION-Valve Feedback	Enabled

**Legend:**  
 S-1 = Header Sensor  
 S-2 = Outdoor Air Sensor  
 S-3 = Return Sensor  
 P-1a, P-1b = System Pump(s)  
 V-1, V-2, V-3 = Sequencing Valves  
 P-2 = DHW Pump  
 DHW = DHW Boiler Sensor

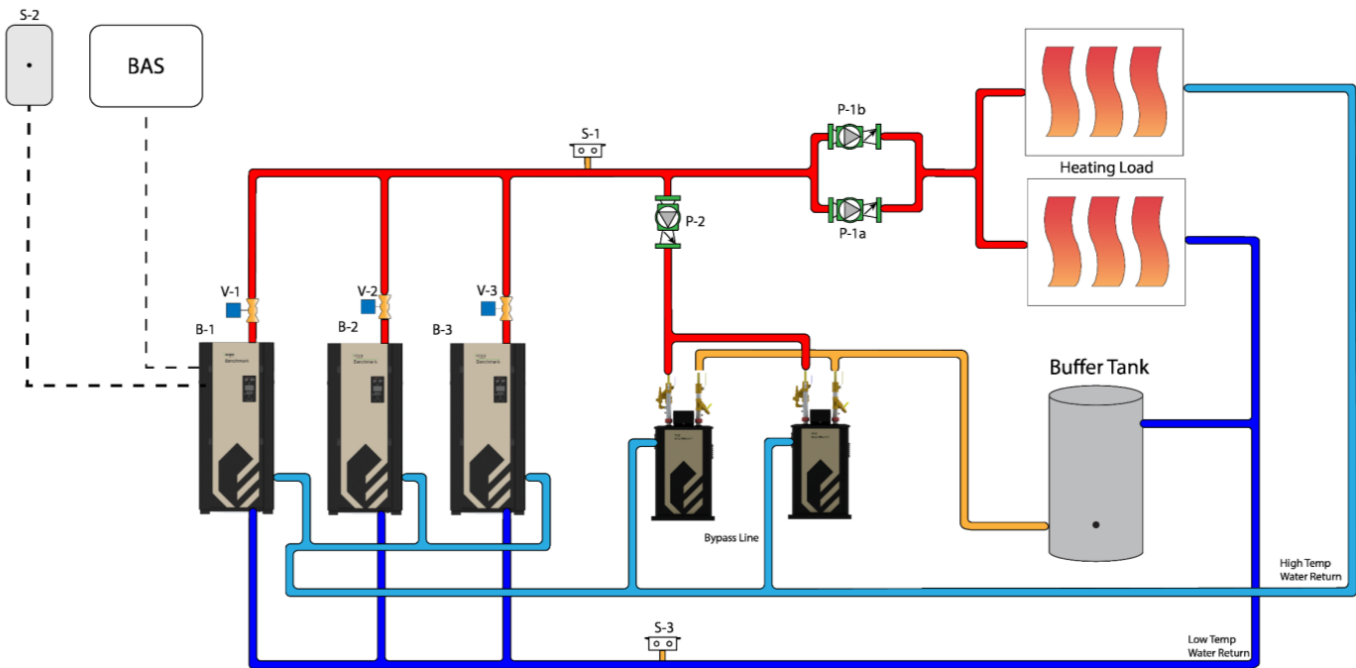

**Diagram 4-10a: Combination System with 2-Port Buffer Tank and Domestic Summer Pump Mode Piping**

# Benchmark Series Boilers Application Design Guide

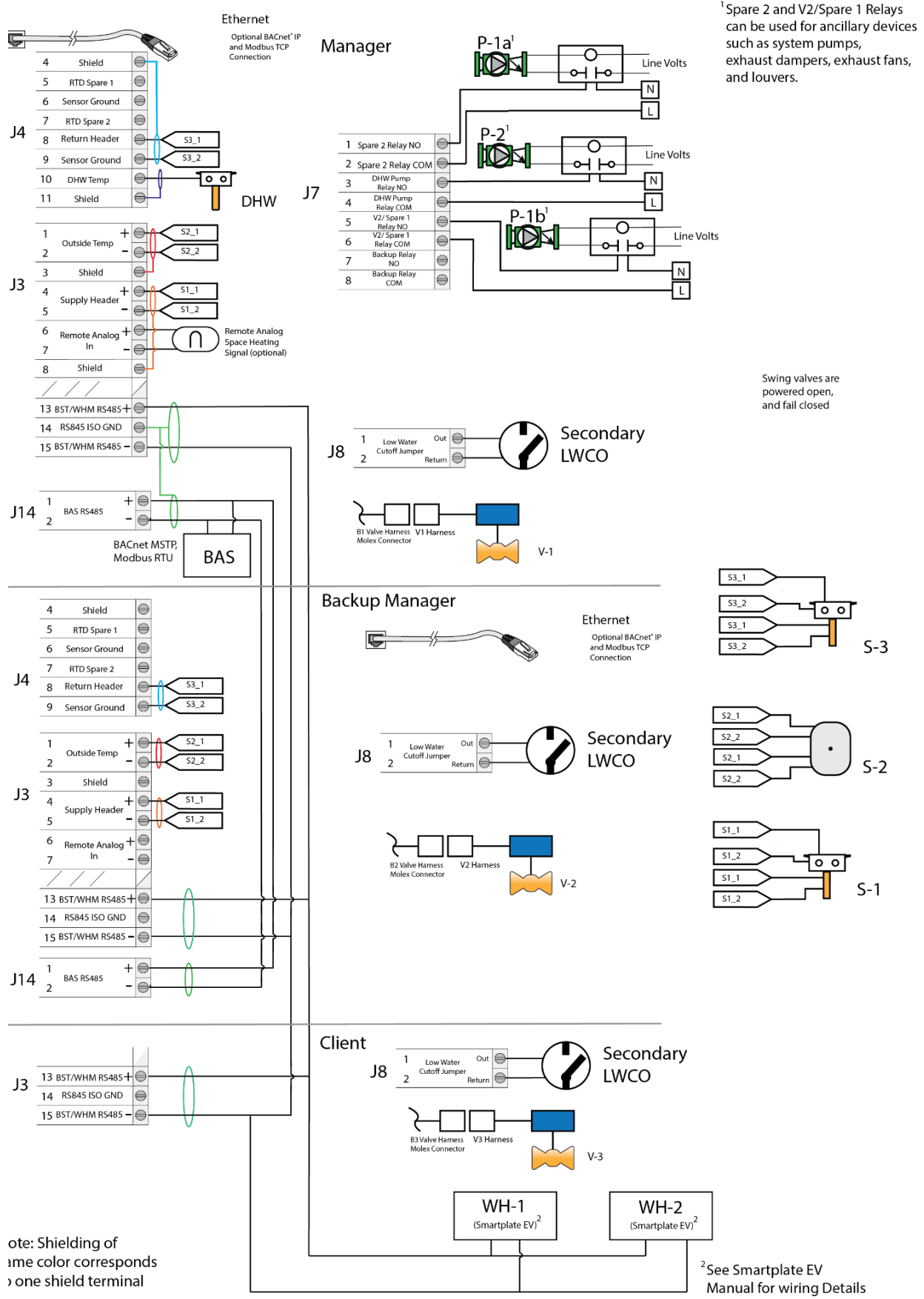

Note: Shielding of same color corresponds to one shield terminal

**Diagram 4-10b: Space Heating with Temperature Boost and 2-Port Buffer Tank Wiring**

**4.11 Space Heating with Temperature Boost and 4-port Buffer Tank**

**Application Description & Features:** AERCO Benchmark boilers are operated via Boiler Sequencing Technology (BST) to provide space heating and domestic hot water generation through AERCO SmartPlate EV water heaters. Space heating supply temperature is maintained as constant setpoint, via outdoor air reset or from remote setpoint command (from building automation system or via remote analog signal). Domestic hot water generation setpoint is a priority: temperature setpoint is boosted when header temperature falls below DHW setpoint. DHW pump is controlled by the DHW temperature sensor to provide boiler water to the water heaters. 4-port buffer tank is utilized to dampen out fast domestic load transitions and minimize boiler cycling. Application utilizes AERCO supplied header sensor, sequencing valves and outdoor air sensor; return header sensor is optional.

- The AERCO Edge Controller sequences the boiler plant for maximum system efficiency by running as many boilers as available, each operating at its most efficient firing rate.
- Sequencing valves isolate standby boilers from the system, reducing the system’s minimum flow requirement.
- Edge[i] controller supports integration with BAS via BACnet MSTP, BACnet IP, Modbus RTU and Modbus TCP.

**Essential System Settings:**

Parameter	Setting
Application	SH+DHW-Stpt Prty
SH Operating Mode	Constant Setpoint, Outdoor Air Reset or Remote Setpoint
DHW Operating Mode	Constant Setpoint
DHW Pump Control Type	Controlled
CASCADE CONFIGURATION-Hdr Temp Sensor	Direct
CASCADE CONFIGURATION-Outdoor Air Temp Sensor <i>(If SH Operating Mode=Outdoor Air Reset)</i>	Direct
VALVE CONFIGURATION-Select Output	Cascade Valve
VALVE CONFIGURATION-Valve Feedback	Enabled

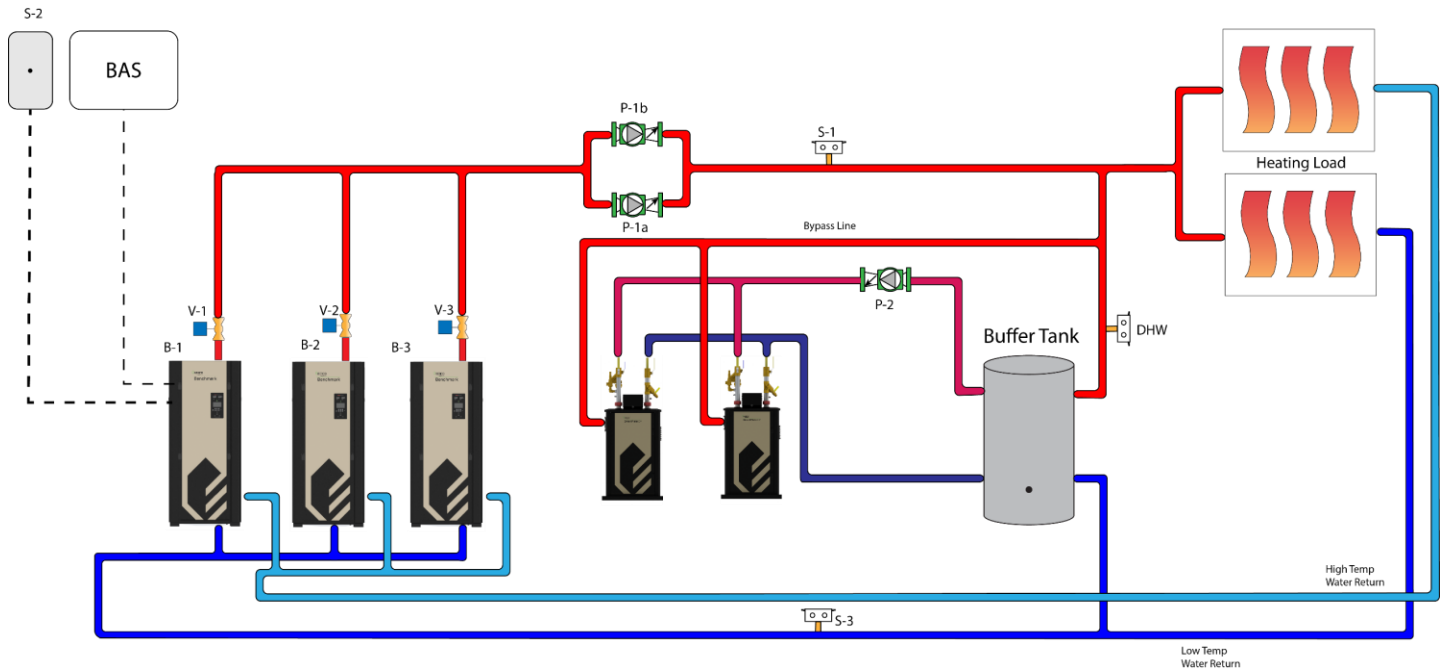

**Diagram 4-11a: Space Heating with Temperature Boost and 4-Port Buffer Tank Piping**

# Benchmark Series Boilers Application Design Guide

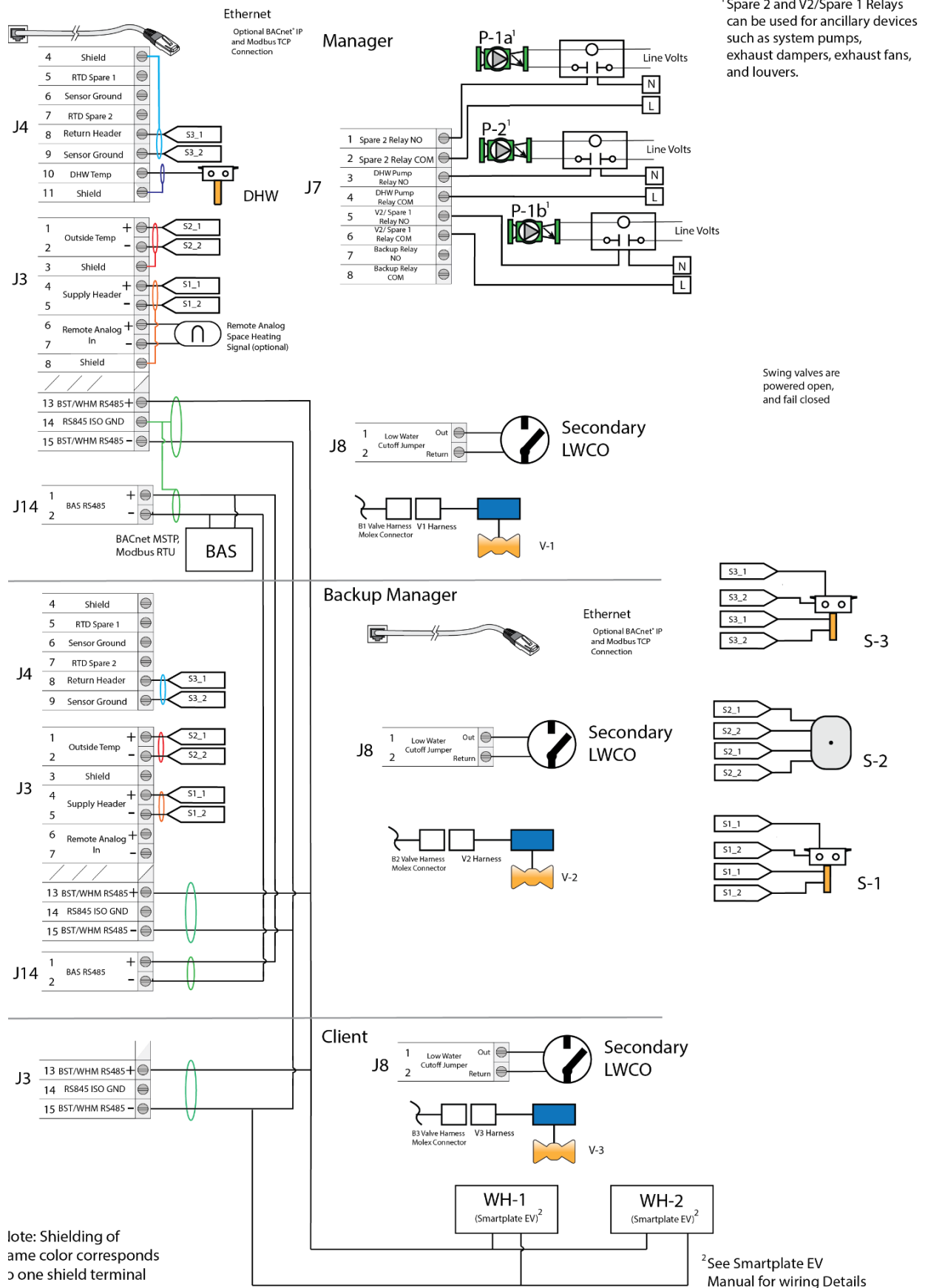

Note: Shielding of same color corresponds to one shield terminal

**Diagram 4-11b: Space Heating with Temperature Boost and 4-Port Buffer Tank Wiring**

**4.12 Space Heating with Temperature Boost and Indirect Storage Tank Water Heater**

**Application Description & Features:** AERCO Benchmark boilers are operated via Boiler Sequencing Technology (BST) to provide space heating and domestic hot water generation through a indirect storage tank water heater. Space heating supply temperature is maintained as constant setpoint, via outdoor air reset or from remote setpoint command (from building automation system or via remote analog signal). Domestic hot water generation setpoint is a priority: temperature setpoint is boosted when header temperature falls below DHW setpoint. DHW boiler pump is controlled by an aquastat to provide boiler water to the indirect storage tank water heater. Application utilizes AERCO supplied header sensor, sequencing valves and outdoor air sensor; return header sensor is optional.

- The AERCO Edge Controller sequences the boiler plant for maximum system efficiency by running as many boilers as available, each operating at its most efficient firing rate.
- Sequencing valves isolate standby boilers from the system, reducing the system’s minimum flow requirement.
- Edge[iii] controller supports integration with BAS via BACnet MSTP, BACnet IP, Modbus RTU and Modbus TCP.

**Essential System Settings:**

Parameter	Setting
Application	SH+DHW-Stpt Prty
SH Operating Mode	Constant Setpoint, Outdoor Air Reset or Remote Setpoint
DHW Operating Mode	Constant Setpoint
DHW Pump Control Type	Controlled
DHW Aquastat Enable	Enabled
CASCADE CONFIGURATION-Hdr Temp Sensor	Direct
CASCADE CONFIGURATION-Outdoor Air Temp Sensor <i>(If SH Operating Mode=Outdoor Air Reset)</i>	Direct
VALVE CONFIGURATION-Select Output	Cascade Valve
VALVE CONFIGURATION-Valve Feedback	Enabled

**Legend:**  
 S-1 = Header Sensor  
 S-2 = Outdoor Air Sensor  
 S-3 = Return Sensor  
 P-1a, P-1b = System Pump(s)  
 V-1, V-2, V-3 = Sequencing Valves  
 P-2 = DHW Pump

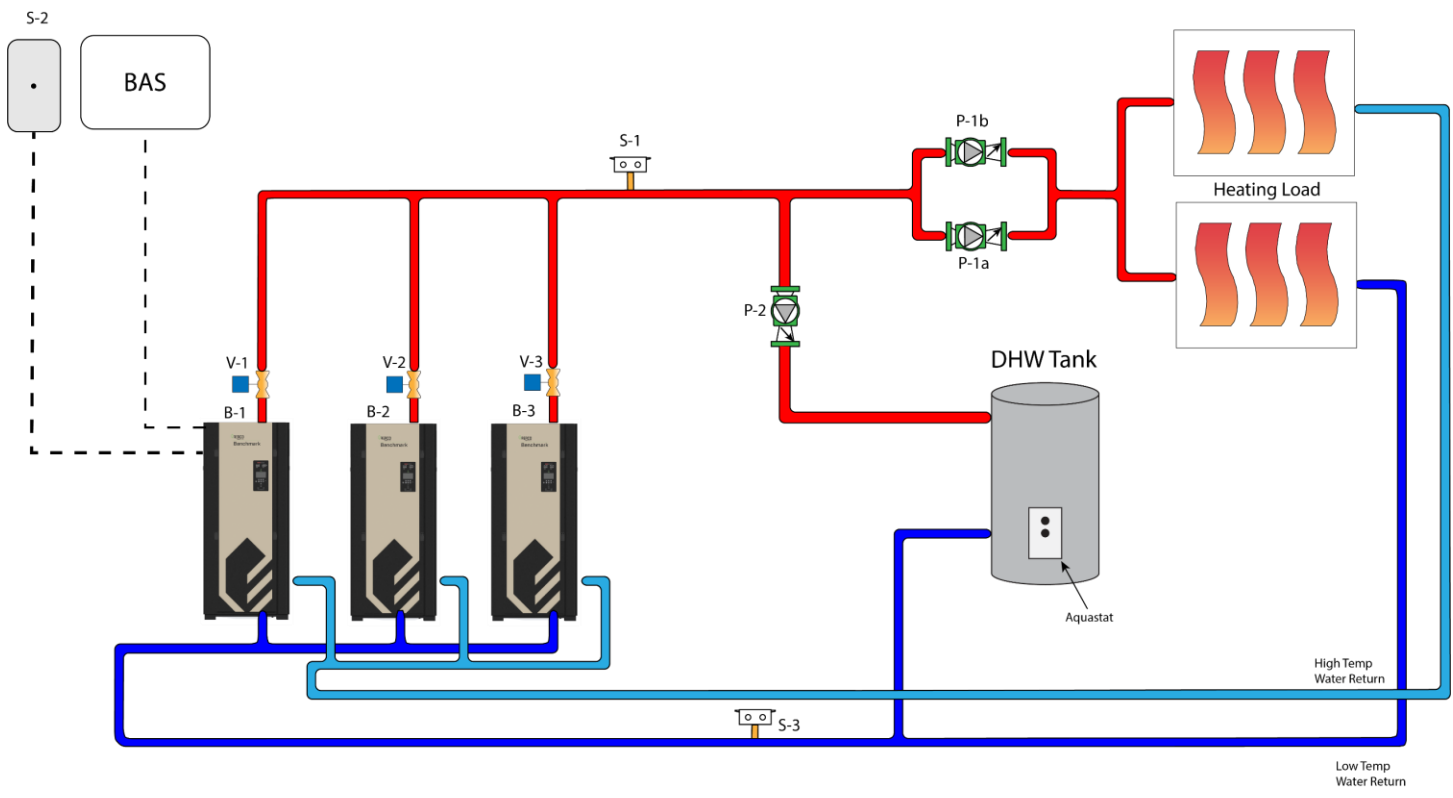

**Diagram 4-12a: Space Heating with Temperature Boost and Domestic Hot Water Piping**

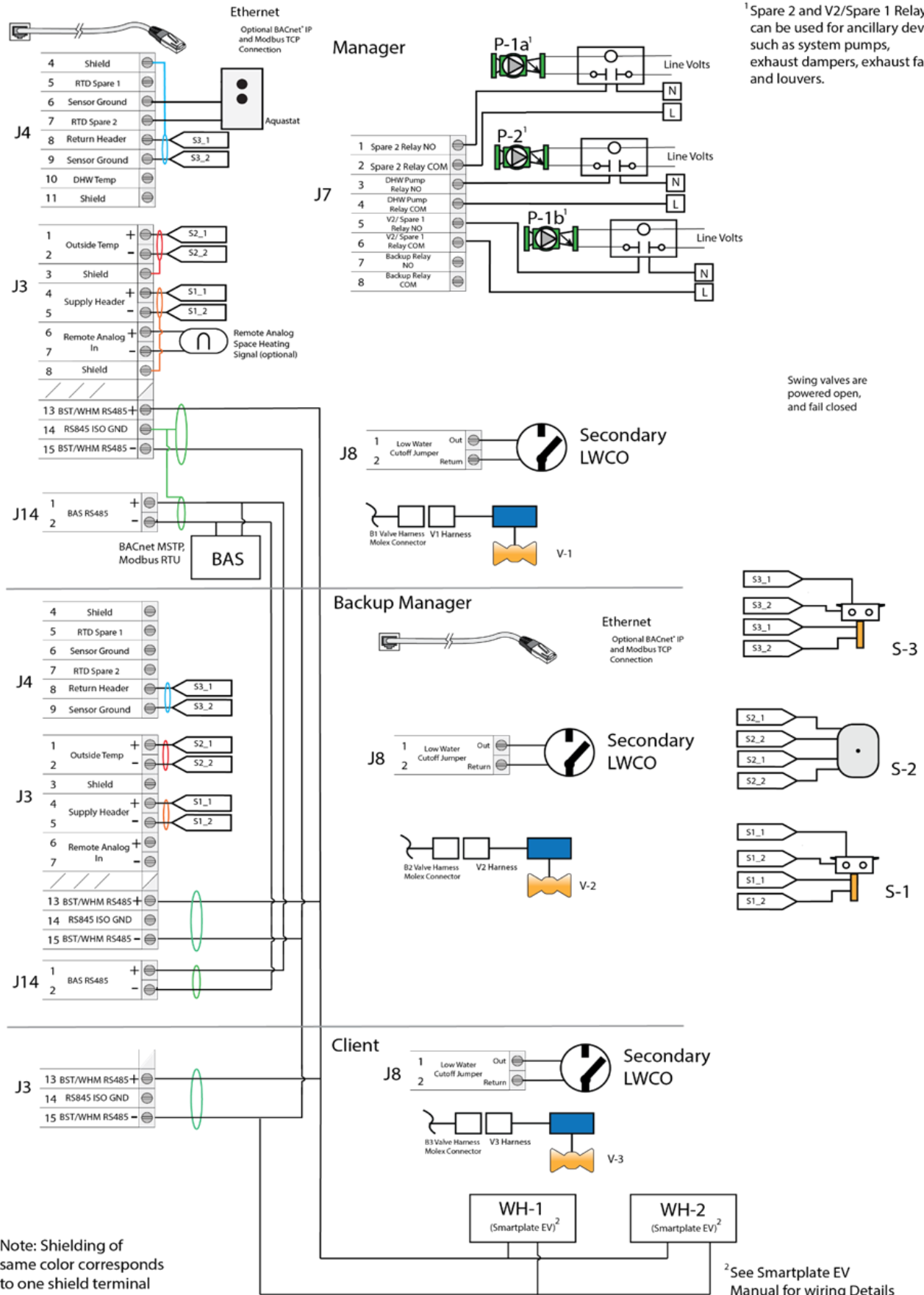

**Diagram 4-12b: Space Heating with Temperature Boost and Domestic Hot Water Wiring**

## 5. INPUT/OUTPUT REFERENCE DIAGRAM

Wiring connections for temperature sensors, control signals, interlocks and auxiliary equipment are made on the Input/Output board. See Benchmark Edge [ii] Installation Manual OMM-0136 for details. For electrical power and emergency shutoff requirements, see Benchmark Electrical Power Guide TAG-0048.

The following relays are rated 120VAC, 3A Resistive (1 A Inductive):

- Spare 2 Relay
- DHW Pump Relay
- V2/Spare 1 Relay
- Backup Relay
- Swing Valve 1 Relay

The following relays are rated 120VAC, 10A Resistive (3A Inductive):

- Fault Relay
- Aux Relay

**NOTE: Remote Interlock BST/Cascade Shutdown:**  
 For remote interlock plant shutdown, connect to terminals 5 and 6 of J4 of the Manager boiler. Remote interlock use must be set to "System Shutdown" or "SH Shutdown" and enabled for remote interlock plant shutdown. **UNDER NO CIRCUMSTANCES** should the plant shutdown remote interlock of the BST manager be used as an emergency shutdown switch for the plant.

**Individual Boiler Remote Interlock:** Terminal 1 and 2 of J6, wire with a separate dry contact from a multi-pole switch only.

