

Series W-W1911-L/G

Fully Lugged Design Butterfly Valve

Size: DN50-DN150(-L) Lever operated
DN50-DN600(-G) Gear operated

The Watts Series W-W1911 butterfly valves are designed and manufactured to meet the stringent requirements of plumbing, HVAC, irrigation, commercial and industrial application. Suitable for use as a bi-directional isolation butterfly valve in dead-end service at full line pressure up to PN16.

Features

- Simple structure, easy to operate
- Simple installation, excellent sealing performance.
- High reliability and long durability
- Position indicators
- Double regulating feature available on request
- Chain wheel operator available upon request

Test Pressures

Shell: 24bar
 Seat: 17.6bar

Material

Component	Material
Body	Ductile Iron
Disc	Stainless Steel (SS316) Aluminum Bronze*
	Ductile Iron (Nickel-plated) Ductile Iron (Epoxy coated)
Seat	EPDM
Stem	Stainless Steel (SS420)

*Contact sales for Aluminum Bronze disc dimensions

Installation Dimensions

1. Lug-type lever operated midline butterfly valve (W-W1911-L ME)

DN	H1	H2	H3	H4	L	L1	□C	D1	nxm	α	D2	D3	D4	nx ϕ d	Torque(N.m)	
															Wet	Dry
50	80	142.7	95	24	215	43	□9	ϕ 125	4xM16	45°	ϕ 89	ϕ 51.7	ϕ 70	4x ϕ 10	15.1	24.2
65	89	155.4	95	24	215	46	□9	ϕ 145	4xM16	45°	ϕ 105	ϕ 63.3	ϕ 70	4x ϕ 10	17.2	32.7
80	95	161.8	95	24	215	46	□9	ϕ 160	8xM16	22.5°	ϕ 120	ϕ 77.7	ϕ 70	4x ϕ 10	23.1	43.7
100	114	177	95	26	215	52	□11	ϕ 180	8xM16	22.5°	ϕ 148	ϕ 103.1	ϕ 70	4x ϕ 10	39.8	72.8
125	127	189.5	95	26	215	56	□14	ϕ 210	8xM16	22.5°	ϕ 170	ϕ 122.2	ϕ 70	4x ϕ 10	61.9	108
150	139	204.2	95	26	215	56	□14	ϕ 240	8xM20	22.5°	ϕ 203	ϕ 154.9	ϕ 70	4x ϕ 10	102	174

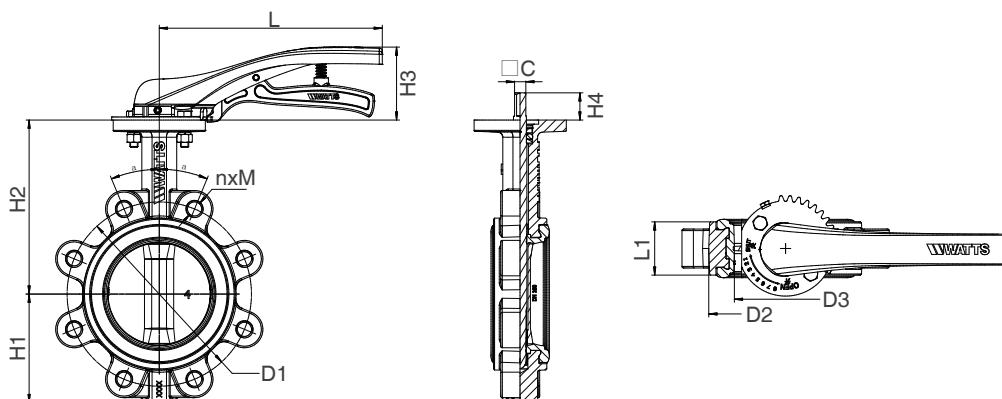

Pressure - Temperature

- Nominal Pressure: PN16
- Temperature Range: -20 C ~ 120 C

Specification

- Design Standard: EN 593, BS 5155/ MSS-SP-67
- Connection Standard: ISO7005-2:1998
BS EN1092:2-1997 PN16
Fully lugged design
- Test Standard: BS EN12266-1
- Connection Type: Lug Type
- Medium: water

Approval



2. Lug-type gear operated midline butterfly valve (W-W1911-G ME)

DN	H1	H2	H3	H4	φ E	L1	□C/D5	b	D1	n×m	α	D2	D3	D4	n×φ d	Torque(N.m)	
																Wet	Dry
50	62	136	66	24	150	43	□9	-	φ 125	4×M16	45°	φ 89	φ 51.7	φ 70	4X φ 10	15.1	24.2
65	70	145	66	24	150	46	□9	-	φ 145	4×M16	45°	φ 105	φ 63.3	φ 70	4X φ 10	17.2	32.7
80	89	151	66	24	150	46	□9	-	φ 160	8×M16	22.5°	φ 120	φ 77.7	φ 70	4X φ 10	23.1	43.7
100	106	170	66	26	150	52	□11	-	φ 180	8×M16	22.5°	φ 148	φ 103.1	φ 70	4X φ 10	39.8	72.8
125	119	190	66	26	150	56	□14	-	φ 210	8×M16	22.5°	φ 170	φ 122.2	φ 70	4X φ 10	61.9	108
150	131	203	66	26	150	56	□14	-	φ 240	8×M20	22.5°	φ 203	φ 154.9	φ 70	4X φ 10	102	174
200	164	245.5	82	33	298	60	□17	-	φ 295	12×M20	15°	φ 255	φ 201.3	φ 102	4X φ 12	192	330
250	199	271	82	26	298	68	□22	-	φ 355	12×M24	15°	φ 303	φ 249.4	φ 102	4X φ 12	323	549
300	230	296	84	26	298	78	□22	-	φ 410	12×M24	15°	φ 355	φ 300.1	φ 102	4X φ 12	490	799
350	288	368	84	40	298	78	φ 31.6 ^{+0.05}	8	φ 470	16×M24	11.25°	φ 405	φ 331.5	φ 102	4X φ 14	625	969
400	331	400	120	52	300	102	φ 33.15 ^{+0.05}	10	φ 525	16×M27	11.25°	φ 470	φ 387.5	φ 140	4X φ 18	846	1307
450	355	422	120	52	300	114	φ 38 ^{+0.05}	10	φ 585	20×M27	9°	φ 525	φ 438.5	φ 140	4X φ 18	1131	1787
500	388	480	150	64	300	127	φ 41.15 ^{+0.05}	10	φ 650	20×M30	9°	φ 578	φ 488.8	φ 140	4X φ 18	1431	2288
600	475	562	150	70	300	154	φ 50.65 ^{+0.05}	16	φ 770	20×M33	9°	φ 693	φ 589.9	φ 165	4X φ 22	2301	3711

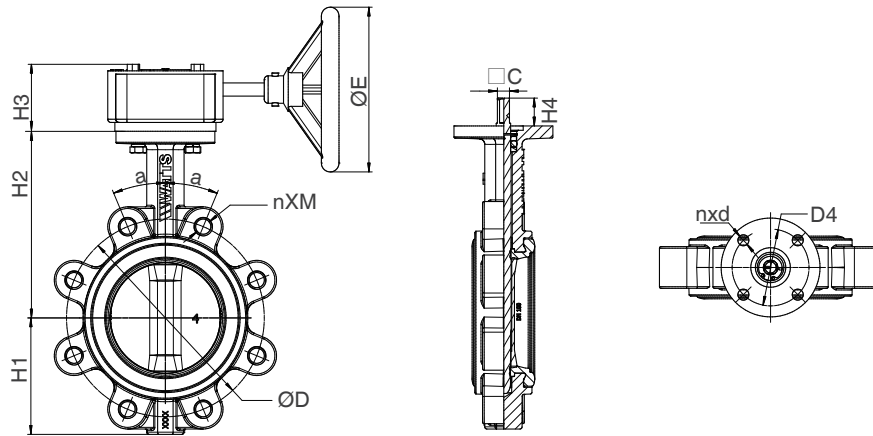

Characteristic Curves

